

 **MOORE
INDUSTRIES**

THZ² & TDZ² HLPRG

May 2016
235-797-00G

Programmable Smart HART
Signal Isolator

THZ² & TDZ² Programmable Smart HART
Signal Isolator



Table of Contents

Introduction	4
About this Manual	4
The THZ² and TDZ²	4
Model and Serial Numbers	4
Specifications	5
Stability and Ambient Temperature Effects Tables	6
Dimensions.....	6-9
Configuring the THZ² and TDZ²	10
Installing the Configuration Software	10
Connecting the THZ² or TDZ² to the PC.....	11
Necessary Equipment Table.....	11
PC Configuration Software Summary	14
Menu and Tool Bar Legend.....	15
Configuration Screens.....	15
Searching for a Connected Unit.....	20
Using the HART Communicator	20
Programming when a Device Description is Available.....	20
The HART Communicator Menu With a Device Description	22
The HART Communicator Menu Without a Device Description.....	27

HART Status Information	28
Installation	31
Mounting the THZ ² and TDZ ²	31
Making the Electrical Connections	31
Recommended Ground Wiring Practices	31
CE Conformity	32
Installation in Hazardous Locations	33
Operation	34
HART Protocol	34
Maintenance.....	34
Customer Support	34

THZ² & TDZ²

Programmable Smart HART
Signal Isolator

Introduction

This is the user's manual for Moore Industries' THZ² and TDZ² (HLPRG: Voltage and Current inputs) Programmable Smart HART Signal Converter. It contains all of the information needed to configure, install, operate and maintain the instruments.

About this Manual

Pay particular attention wherever you see a "**Note**", "**Caution**" or "**WARNING**".

Note— Information that is helpful for a procedure, condition or operation of the unit.

Caution— Hazardous procedure or condition that could damage or destroy the unit.

WARNING— Hazardous procedure or condition that could injure the operator.

Default/Factory Configurations

The following are the default factory settings for your unit.

THZ²

Input: Current 4-20mA
Filter: 60Hz
Broken Wire: Enabled, 3
Running Average: Disabled
PV Damping: Disabled
AO: 4-20mA
Under Range Minimum Value: 3.8
Over Range Maximum Value: 21.6
Fail Mode: Low, 3.6mA

TDZ²

Input: Current 4-20mA
Filter: 60Hz
Broken Wire: Enabled, Level 3
Running Average Filter: Disabled, 1
PV Damping: Disabled, 0s
Display Source: PV
Decimal Places: 3
Output: 4-20mA
Under Range Min Value: 3.8
Over Range Max Value: 21.6
Sensor Fail Mode: Low, 3.6mA

The THZ² and TDZ²

The THZ² and TDZ² are 2-wire (loop-powered), user-configurable, HART[®]-based signal isolator. Their size, accuracy and compatibility make them the ideal solution when measurements must be made in remote or otherwise difficult-to-access locations.

The THZ² and TDZ² allow for configuration through two methods. You may use your PC's RS-232 serial port or USB port and Moore Industries' PC Configuration Software (once installed onto your PC). All configuration parameters are available through the PC Configuration Software.

The second method is to connect a HART Communicator and HART modem into your process loop. You must ensure that your communicator is configured with the THZ² and TDZ² Device Description (DD). You may then configure most parameters through the Communicator. Custom Curve variables cannot be entered using the Communicator. They must be configured using the PC Configuration Software.

Model and Serial Numbers

Moore Industries uses the model and serial numbers of our instruments to track information regarding each unit that we sell and service. If a problem occurs with your instrument, check for a tag affixed to the unit listing these numbers. Supply the Customer Support representative with this information when calling.

Specifications

<p>HART Specifications</p> <p>Address Range: 0-15 (1-15 are for multidrop loops)</p> <p>Transmission Speed: 1200 bps</p> <p>Character Format: 1 Start Bit - 8 Data Bits - 1 Odd Parity Bit - 1 Stop Bit</p>	<p>Performance (Continued)</p> <p>Over-voltage Protection: Current: 100mA, maximum; Voltage: ±18Vdc maximum</p> <p>Digital Input Filter: User-programmable; 50/60 Hz</p> <p>Power Supply Effect: ±0.002% of span per 1V change</p> <p>Load Effect: Negligible within specified power limits</p> <p>Load Capability: (500 ohms@24V) Supply Voltage - 12V $\frac{\quad}{0.024A} = \text{Ohms}$</p> <p>Burnout Protection: User-programmable, Upscale 20 to 23.6mA; Downscale 3.6 to 4.0mA</p> <p>Output Current Limiting: User-programmable, 3.6 to 4.0mA and 20 to 23.6mA for input under/over range; 25mA, maximum (hardware limit)</p> <p>Input Impedance: Voltage: 1Mohm, nominal; Current 20ohms, nominal</p> <p>Damping: User set; 0-30 seconds</p> <p>Resolution: Input, 20-bit; Output, 16-bit</p> <p>Power Supply Requirement: 12-30Vdc for I.S. version; 12-42Vdc for standard version</p> <p>Display Type (TDZ² only): TDZ²; Top Row, 10mm (0.4 in) high black digits on a reflective background; Bottom Row, 6mm (0.225 in) high digits on a reflective background; Two-digit HART address indicator</p> <p>Format: Two rows of five alphanumeric characters</p> <p>Decimal Points: Can be user-set to enable automatic adjustment of decimal point to 2 decimal-places; Allowed decimal places: Auto, 1, 2 or 3</p> <p>Range: -99999 to 99999</p> <p>Minimum Display Span: 1.00</p>	<p>Ambient Temperature</p> <p>Operating Range: -40°C to +85°C (-40°F to +185°F);</p> <p>Storage Range: -40°C to +85°C (-40°F to +185°F)</p> <p>Relative Humidity: 0-95%, non-condensing</p> <p>Ambient Temperature Effect: Refer to Table 2</p> <p>Startup Time: <0.5sec, maximum</p> <p>Noise Rejection: Common mode, 100dB@50/60Hz; Normal Mode: Voltage, 70dB @1Vp-p@50/60Hz; Current, 70dB@50mA p-p@50-60Hz</p> <p>RF/EMI Immunity: THZ²: HPP and DIN: 10V/m@80-1000MHz, 1kHz AM, when tested according to IEC 61326; With -RF DIN Option: 20V/m@80-1000MHz, 1kHz AM, when tested according to IEC 61326; TDZ²: 20V/m when tested according to IEC 61326</p> <p>Weight</p> <p>THZ² DIN: 221g (7.9 oz)</p> <p>THZ² HPP: 91g (3.2 oz)</p> <p>THZ² HPP in LH1: 423g (15.1 oz)</p> <p>THZ² HPP in LH2: 644g (22.9 oz)</p> <p>TDZ² HP: 182g (6.4 oz)</p> <p>TDZ² HP in BH: 1.4kg (50.2 oz)</p> <p>TDZ² HP in D-Box: 672g (23.4 oz)</p>
---	--	---

Specifications and information subject to change without notice.

THZ² & TDZ²

Programmable Smart HART
Signal Isolator

Table 1. Long-Term Stability Table

Stability (% of maximum span)	Standard Stability Version					
	Input to Output			Input to HART		
	1 yr	3 yrs	5 yrs	1 yr	3 yrs	5 yrs
Voltage	0.014	0.18	0.23	0.066	0.114	0.147
Current	0.093	0.16	0.21	0.047	0.081	0.105

Table 2. Ambient Temperature Effects Table

Input Type	Digital Accuracy per 1°C (1.8°F) change in Ambient	Analog Accuracy per 1°C (1.8°F) change in Ambient
Voltage	1mV	0.004% of span (16mA)
Current	2 microamps	

Figure 1. THZ² Hockey-Puck (HPP Housing) Dimensions

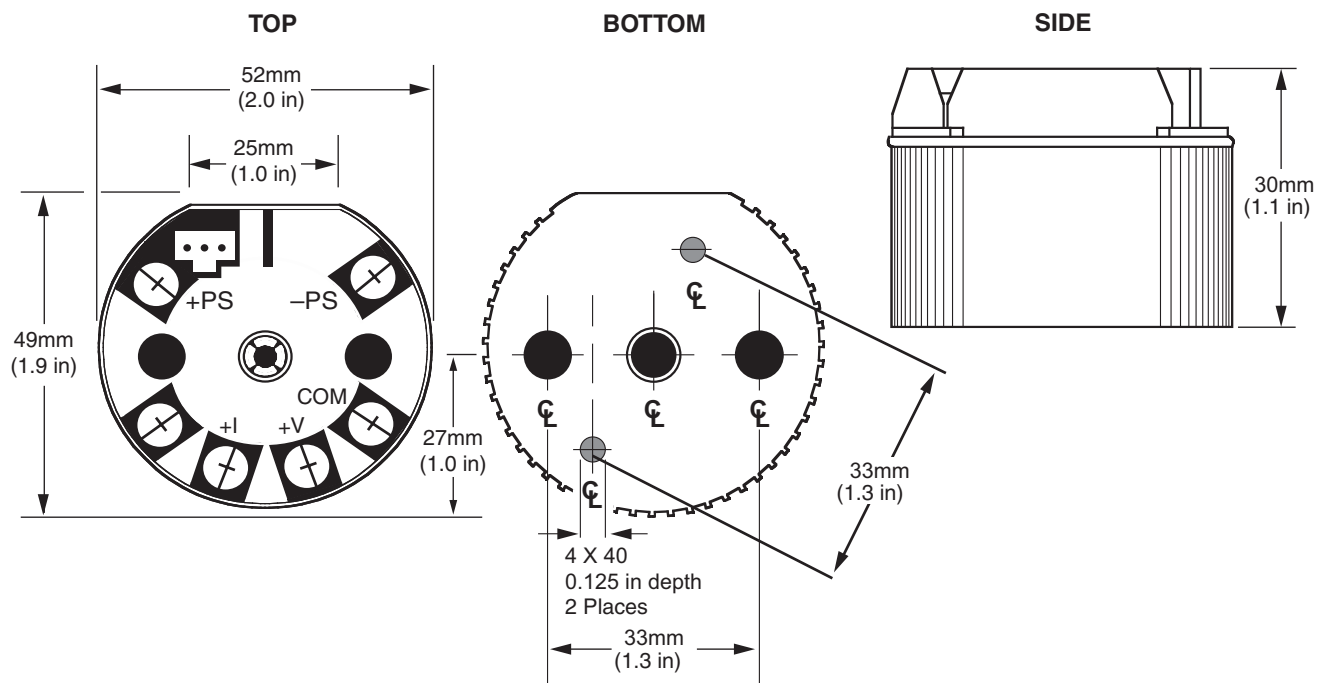

THZ² & TDZ²

Programmable Smart HART
Signal Isolator

Figure 2. TDZ² Hockey-Puck (HP Housing) Dimensions

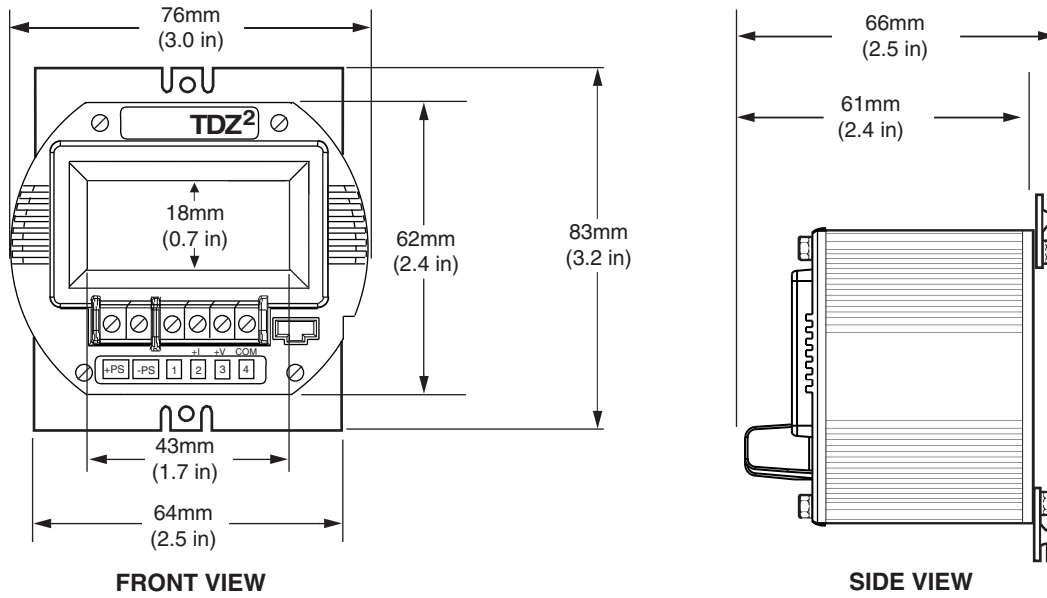
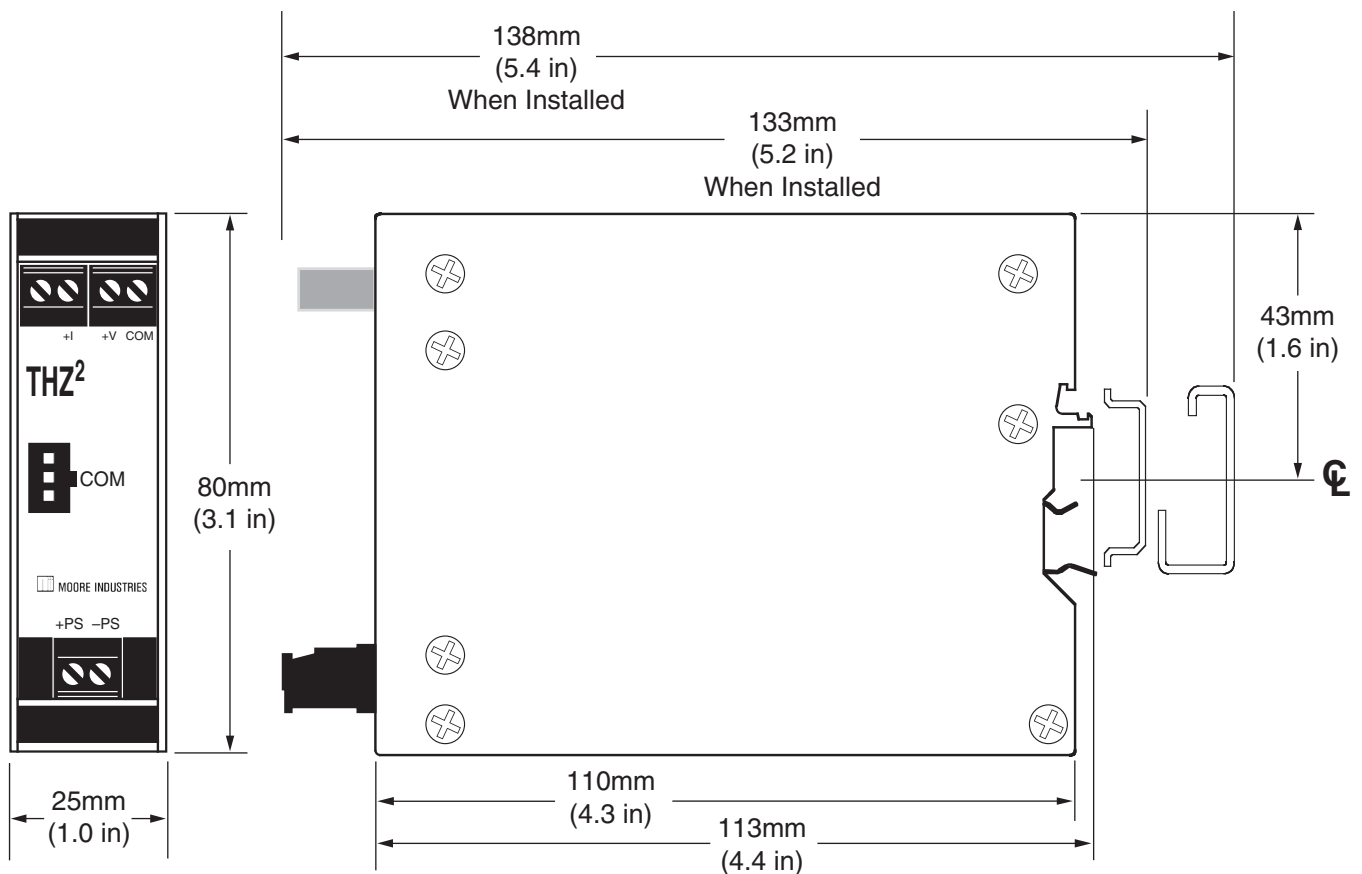

Figure 3. THZ² DIN Dimensions



THZ² & TDZ²

Programmable Smart HART
Signal Isolator

Figure 4. BH Housing Dimensions (For use with the TDZ²)

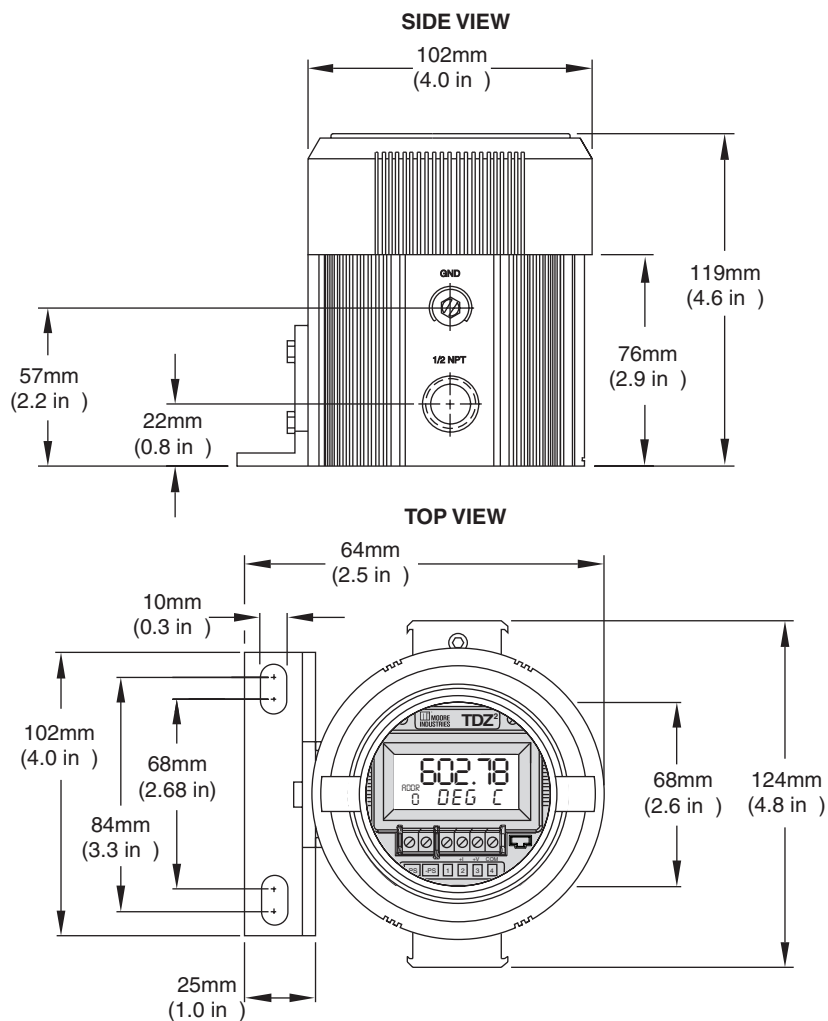

THZ² & TDZ²

Programmable Smart HART
Signal Isolator

Figure 5. LH Housing Dimensions (For use with the THZ² HPP)

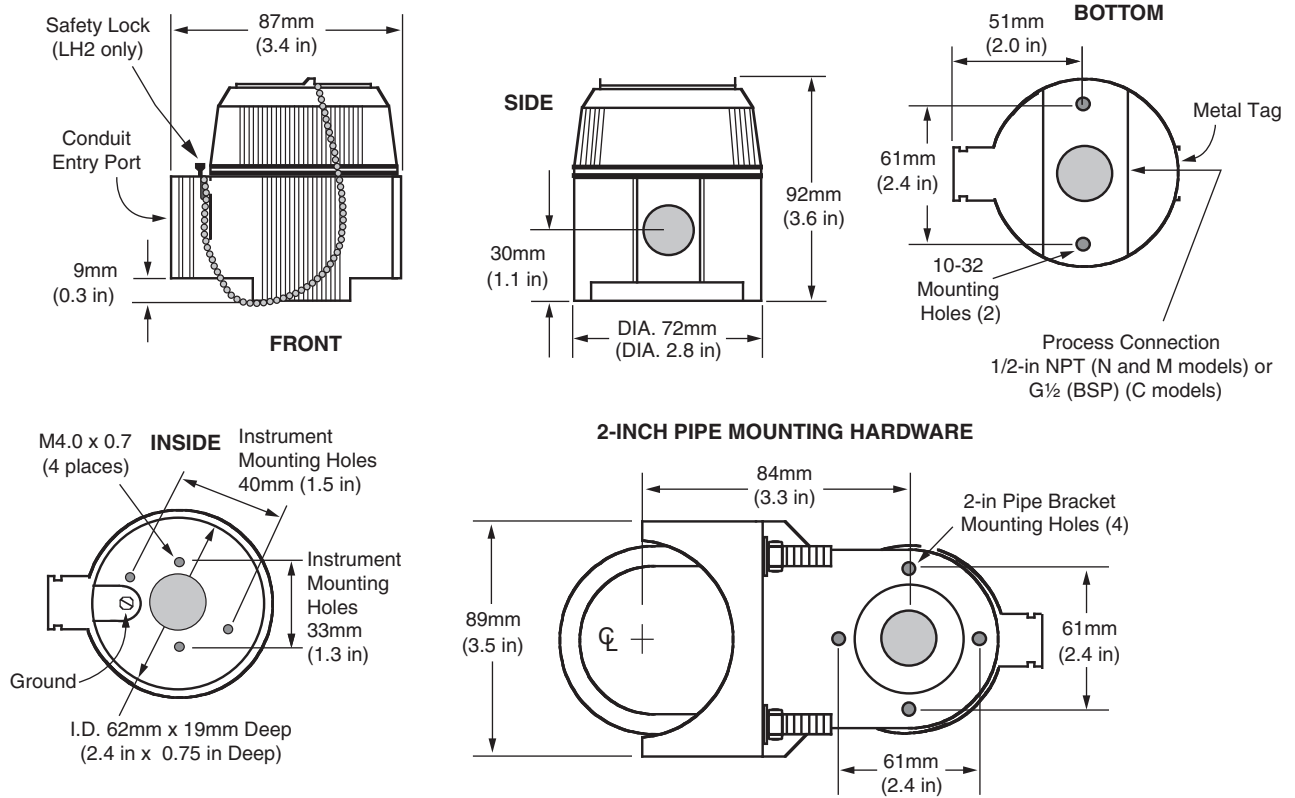
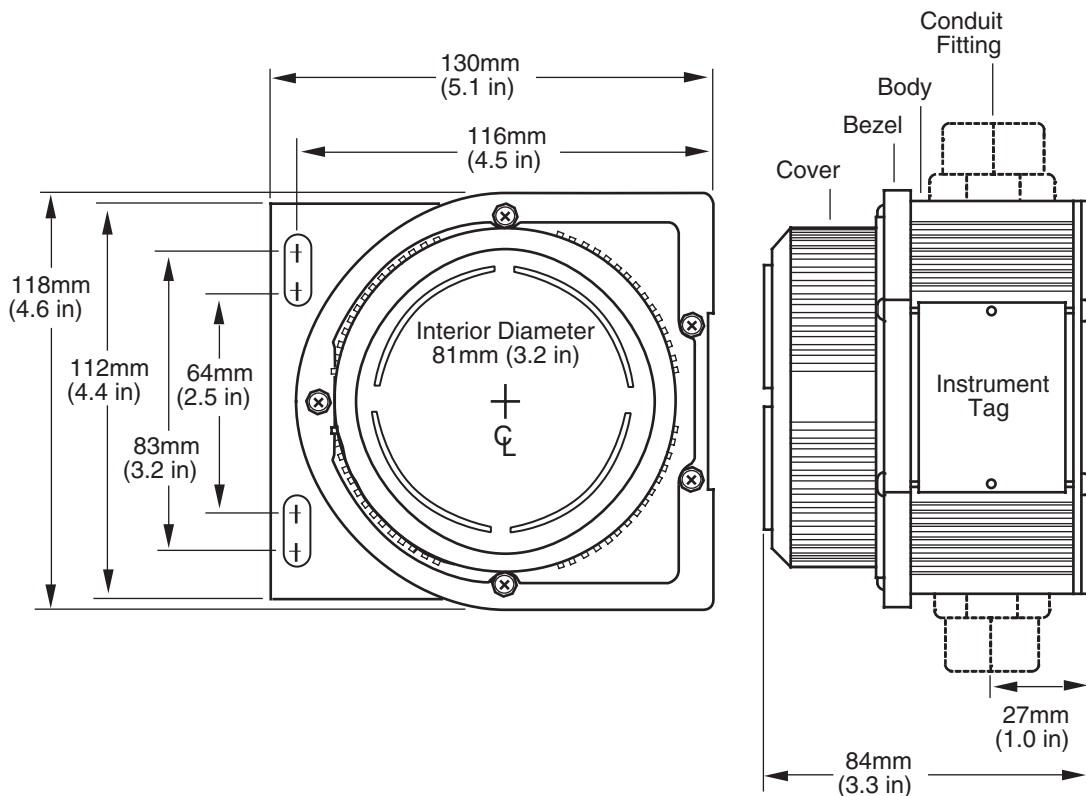

Figure 6. D-BOX Housing Dimensions (For use with the TDZ²)



THZ² & TDZ²

Programmable Smart HART
Signal Isolator

Configuring the THZ² and TDZ²

One of the benefits of these transmitters is that there are no internal or external controls to adjust or settings to change. All operating parameters are set using either a HART Communicator or a PC and Moore Industries' Intelligent PC Configuration software.

The software settings are downloaded to the transmitter in the form of a Configuration File and stored in the instrument's memory. You can save a backup copy of the file on your PC hard drive or external media. The transmitter communicates with the PC through an RS-232 port or USB. A HART modem connection to the PC's serial port may also be used.

You can configure the THZ² or TDZ² with either a standard HART Communicator or our PC software. Figures 7 and 8 (depending upon your instrument's housing) and Table 5 provide the information you need to configure your unit.

Using a PC

If you are going to use a PC to configure your unit, first install the software as described on the next page, then setup the hardware as shown in Figures 7 or 8 (depending upon your instrument's housing).

Installing the Configuration Software

Refer to Table 3 for the equipment needed.

1. Insert the *Moore Industries Interface Solution PC Configuration Software* CD into the CD drive of the PC. Access the CD and open the *THZ2_TDZ2 PC Configuration Software* folder.
2. Double-click the installation program located in the folder. Follow the prompts to correctly install the program.

Once the Configuration Program is installed on the PC, the THZ² or TDZ² can be connected to equipment to simulate input and monitor output. You can then change the transmitter's operating parameters.

No Transmitter Needed

It is not necessary to connect the transmitter to a PC to create configuration files using the software. The Configuration Program can be run without connecting a transmitter, and **most** parameters can be set without benefit of input from a sensor or transmitter.

This makes it easy to create a set of operating parameters, save them to external media, and download them to one or more transmitters at a later time.

The THZ² or TDZ² **must** be connected to the PC in order to: trim input, trim output, assign a tag, perform a loop test, receive (via download) a configuration file and save the configuration file from the transmitter's memory.

Connecting the THZ² or TDZ² to the PC

To set any of the options, you must first connect the unit to the PC. The THZ² and TDZ² all have the same terminal designations regardless of housing style, and all can be setup using the connections shown in Figures 7 and 8 (depending upon your instrument's housing).

Establish a simple current loop for the transmitter by connecting a 24 Volt power supply, a 250 ohm resistor and the transmitter in series. See Table 3 for information on the necessary equipment.

Connect your instrument to the PC via the RS-232 serial port using Moore Industries Interface cable or USB cables listed in Table 3.

A HART modem may also be used to connect your unit to the PC. Connect the RS-232 end of the modem to the PC's COM port, then connect the HART output end of the modem (two hook-up wires) across the transmitter or the load resistor. For hook-up diagrams, refer to Figures 7 or 8 (depending upon your instrument's housing).

Table 3. Necessary Equipment Table

Device	Specifications
Current or Voltage Source	Accurate to $\pm 0.05\%$ of span for the intended application
Power Supply	24Vdc, $\pm 10\%$
Precision Load Resistor	250 ohms, $\pm 0.01\%$ HART specifies that total loop resistance is to be maintained between 250 ohms and 1100 ohms.
Multimeter (optional)	Accurate to $\pm 0.025\%$ of span; e.g., Fluke Model 87
Personal Computer (Required only if using a PC for setup)	Microsoft Windows based PC; 16Mb free RAM; 20MB free disk space on hard drive Microsoft Windows XP, Vista or 7 1 (one) serial port or one available USB port
Moore Industries Interface Cables	803-040-26, Isolated Interface Cable 803-039-26, USB cable 208-236-00 or Fuse Protected USB Cable 804-030-26
HART Modem Cable (Required only if using a PC)	Moore Industries part number 803-048-26 , or equivalent
Moore Industries PC Configuration Software (Required only if using a PC)	Version 1.0 or greater, successfully installed to the hard drive
HART Communicator (Required only if NOT using a PC)	Fisher-Rosemount Model 375/475 or equivalent (with THZ ² /TDZ ² Device Description loaded)

THZ² & TDZ²

Programmable Smart HART Signal Isolator

Figure 7. THZ² (HPP) and TDZ² (HP) Hook-Up Diagrams

THZ² (HPP) Hook-Up

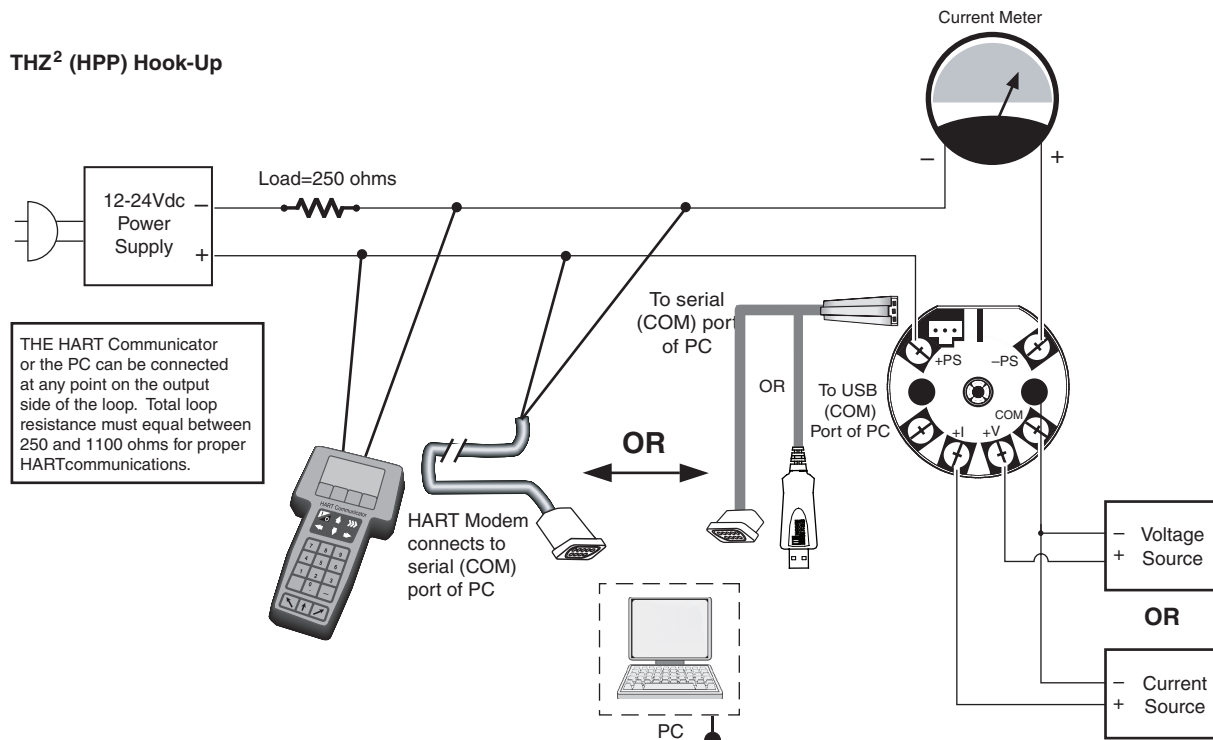

TDZ² (HP) Hook-Up

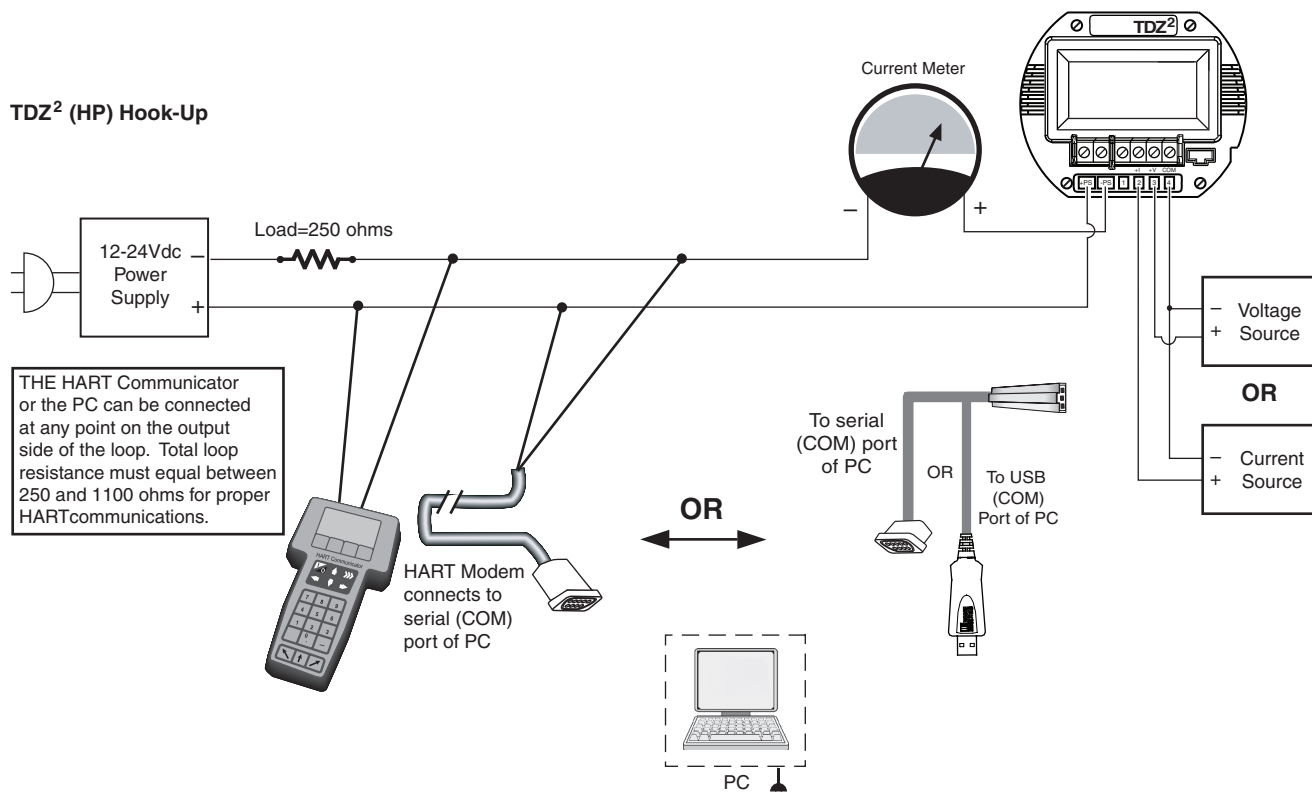

NOTE:

1. Terminal blocks can accommodate 14-22 AWG (2.0-0.3mm²) solid wiring.
2. HP Housing terminals utilize M2.6 screws. Tighten terminals to 2.8 in lb (0.31Nm) (maximum).
3. HPP Housing terminals utilize #4 screws. Tighten terminals to 4.7 in lb (0.53Nm) (maximum).

THZ² & TDZ²

Programmable Smart HART
Signal Isolator

Figure 8. THZ² DIN Hook-Up Diagram

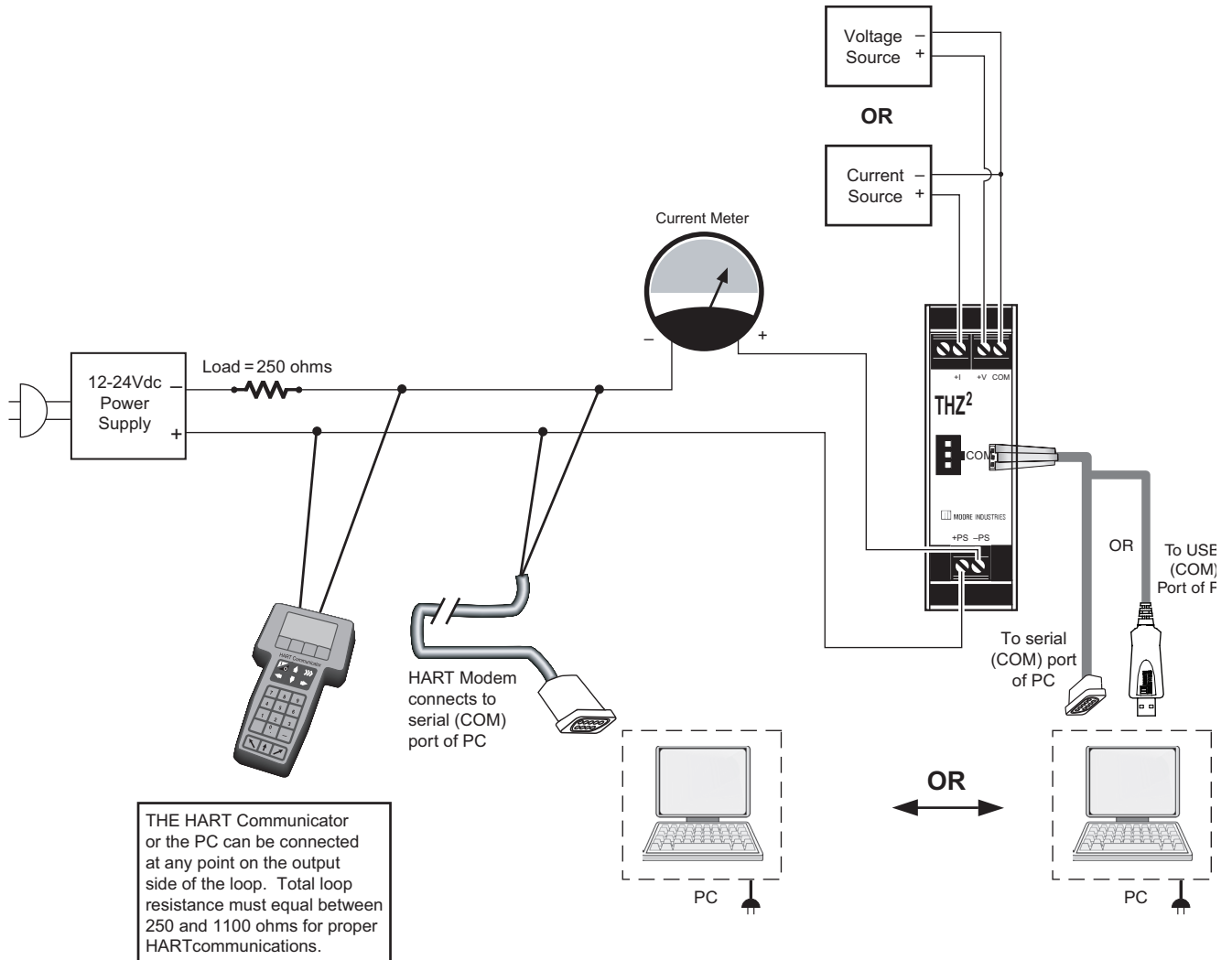

NOTE:

1. Terminal blocks can accommodate 14-22 AWG (2.0-0.3mm²) solid wiring.
2. DIN Housing terminals on HLPRG input instruments utilize #6 screws. Tighten terminals to 5.0 in lb (0.56Nm) (maximum).

THZ² & TDZ²

Programmable Smart HART
Signal Isolator

PC Configuration Software Summary

Figure 9. THZ²/TDZ² PC Configuration Software Main Screen

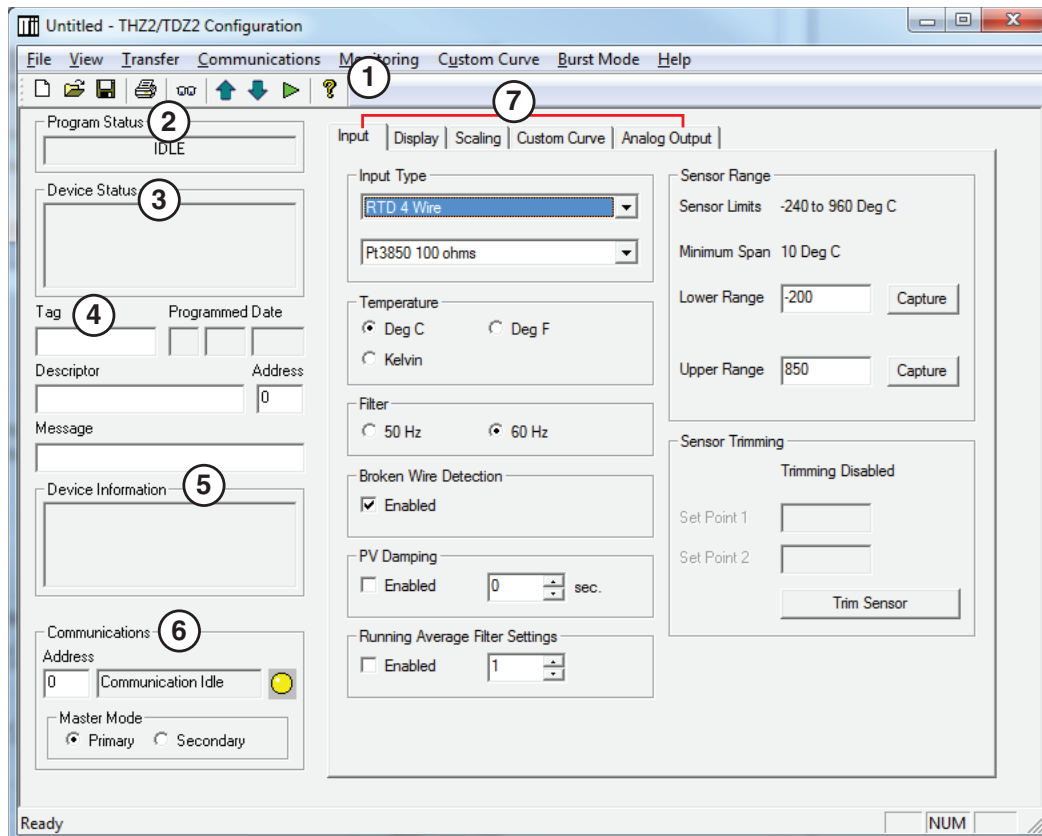

Once the default configuration has been saved to your PC or external media, it is safe to program other parameters. The PC Software is made up of these sections:

1. Menu Bar/Tool Bar– Dropdown menus and corresponding icons allow you to perform various functions throughout the PC Configuration Program. Refer to the *Menu and Tool Bar Legend* for a complete description.

2. Program Status– This portion of the program displays the activity of the connected unit. It will display such messages as: Idle, Monitoring, Uploading and Downloading.

3. THZ2/TDZ2 Status– Indicates if there are problems or faults with the instrument.

4. Identification Parameters– Use this parameter to place an identifying *Tag* (8 alphanumeric characters, maximum), *Descriptor* (16 alphanumeric characters, maximum) or *Message* (32 alphanumeric characters, maximum). Use the *Address* box to change the unit's address (0-15).

To utilize a longer Tag identifier (up to 32 characters, maximum) you may access the *Long Tag* feature located in the *View* dropdown menu. Enter the desired information and click *Set*. To view the Long Tag, click *Read*.

5. THZ2/TDZ2 Device Info– This “read-only” display indicates instrument configuration and device identification.

6. Communications– Notifies user of current PC connection/communications status. The address displayed in the *Address* box must match the address of the unit if HART Communications are being used.

7. Input/Display/Scaling/Custom Curve/Analog Output– These tabs change the right side of the screen to allow you to set the appropriate part of the THZ²'s and the TDZ²'s configuration. See corresponding sections of this manual for additional information regarding these tabs.

Figure 9-B. THZ²/TDZ² PC Configuration Software Main Screen

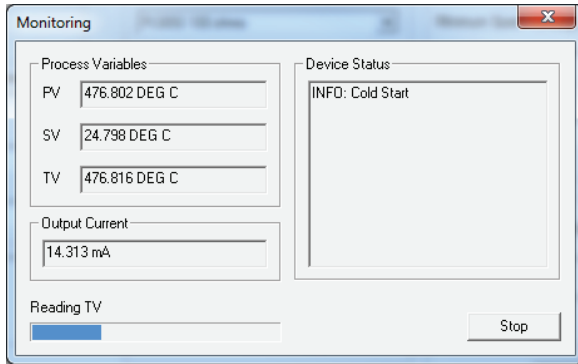

When Monitoring is selected the Process Variable window will appear and display the present Process Variable readings along with Device Status and Output Current.

Note:

When Monitoring user is unable to make any changes to configuration.

Menu and Tool Bar Legend

- File Allows such functions as New, Open, Save and Print functions
- View Controls whether Tool and Status Bars are viewed on the screen as well as Additional Status Information, Long Tag and Device Information
- Transfer Allows you to Upload and Download configurations and perform an Address Search
- Communications Allows selection of PC COM ports as well as Communication Method (Auto, RS232 or HART)
- Monitoring Allows you to Monitor and Stop monitoring processes
- Custom Curve Provides functions specific to your Custom Curve table
- Burst Mode Allows you to enable Burst Mode
- Help Displays the version of the PC Configuration Program

Configuration Screens

Note:

Unless otherwise noted, ensure that the PC Configuration Program is idle before making any selections or configuration changes to the program. Also, when attempting to download or upload, monitoring must be stopped. To do this, click Stop in the Monitoring dropdown menu, or click the Stop Monitoring icon on the Tool Bar.

Input

Figure 10. Input Tab

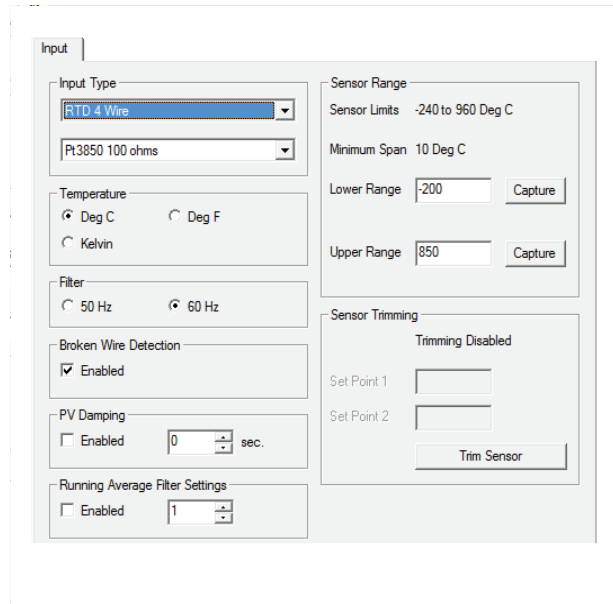

Input Type– Select your input type and the respective range of your input.

Filter– This setting is used to configure the input filter. The filter is designed to reduce the effects of mains-induced noise. The input filter frequency value should be set to the frequency of the local AC supply—either 50Hz or 60Hz.

Broken Wire Detection– If enabled, the THZ² and TDZ² monitor the process variable during operation. If the monitored value falls equal to, or below, a set value, then a state of Broken Wire is declared.

THZ² & TDZ²

Programmable Smart HART Signal Isolator

1. Check the “Enabled” box in order to activate Broken Wire Detection.
2. In the *Level* textbox, enter the value you choose as your limit. The value that you enter must be greater than zero and less than your *Lower Range* value (see *Input Range*).

If a failure is detected, a message will appear in the *THZ2/TDZ2 Status* box.

Running Average Filter Settings– This function is for filtering the input signal. The THZ² and TDZ² provide this filter with a user-selected range between 1 and 16. Factory default is 1.

Note:

A higher Running Average Filter setting provides smoother output transitions; however, reduces response time. Conversely, a lower setting provides a faster response time, but may seem more unstable.

PV Damping–PV Damping allows you to introduce a delay into the response of your unit in order to stop short-lived spikes from initiating faults and generating fault messages.

The configured damping period will determine the time response that the analog output will take to achieve a 66% change in output in response to a stepped input.

To enable PV Damping, select the *Enabled* button. Use the arrows to select a value between 1sec and 30sec.

Input Range– Allows you to set your upper and lower range values within the range chosen in the *Input Type* section.

The desired Upper and Lower Range settings can be entered via your PC keyboard or captured. To capture an input, follow the steps below.

1. Apply the desired Upper Range input and press the corresponding *Capture* button.
2. Next, apply the desired Lower Range input and press the corresponding *Capture* button.

Input Trimming– Input Trimming increases the measurement accuracy of your instrument by matching the reading of its actual input, to either a calibrated source or the device to which it is connected. This verifies that the input to the transmitter is being interpreted correctly.

You may trim any point between 0% and 100% along the scale. Note that one-point trimming applies an offset to the sensor reading, while two-point trimming applies both an offset and a gain.

Follow the steps below in order to perform sensor trimming.

1. Select either *1 Point* (one-point trimming) or *2 Points* (two-point trimming) by clicking the appropriate button. Each pair consists of *Set Value* and *Trim* fields.
2. Enter the values that require trimming into the *Set Value* field and click *Set*.
3. Apply the targeted signal to the input, wait until it settles, and click *Trim* to capture the measured value. If you chose *2 Points*, repeat the step above for the second point.

Note:

*Once you have configured all parameters, download to the unit by selecting *Download* in the *Transfer* dropdown menu located in the *Menu Bar*. Or, click the  button in the *Tool Bar*.*

Display (TDZ² Only)

Figure 11. Display Tab

Display Source– Select how your reading is displayed.

Primary Variable–The reading will be displayed as the Primary Variable value.

Output Current–Your reading will be displayed as the output current value.

Toggle PV / mA– Every four seconds your display will toggle between the primary variable and mA (current) reading.

Percent of Range– Selecting this allows your instrument to display its output in the percent of the range at which the output current is transmitting (0-100%).

Custom Label– The *Custom Label* is used to display a calculated or scaled variable. Clicking the *Use custom label* box causes the instrument to always display the custom label as Engineering Units (EGU).

1. Check the *Use custom label* box.
2. Enter the label you wish viewed into the text box. This value is limited to five characters.

Precision– Select the number of decimal places (up to three) of your display.

Note:

Once you have configured all parameters, download to the unit by selecting *Download* in the *Transfer* dropdown menu located in the *Menu Bar*. Or, click the  button in the *Tool Bar*.

Scaling

Figure 12. Scaling Tab

Note:

Using the *Scaling* feature will disable the *Custom Curve* capability. Since both are scaling features used to manipulate the appearance of your process variable, only one of these functions may be used at a time.

Scaling– This allows you to customize your display for your application. By example, if your process is sending a 4-20mA signal to the THZ² or TDZ² and you wish to view the input as 0-100% then this can be accomplished with the *Scaling* feature.

To scale your instrument, perform the following steps:

1. Check the *Enabled* box. The *Input Range* boxes will display the range selected in the *Input Type* section of the *Input* screen.
2. In the *Scaled to* text boxes, enter the values you wish displayed when your input is at its Zero Range and Full Range.

Once downloaded, your unit will display the scaled values on its LCD and through HART communication.

Scaling PV Units of Measure– Use this to select a preset HART EGU process variable display for your scaled values. These HART EGU codes are compatible with HART Revision 5, and earlier, communications.

To customize your display and set your own EGU, open the *Display* screen and use the *Custom Label* feature.

Note:

Once you have configured all parameters, download to the unit by selecting *Download* in the *Transfer* dropdown menu located in the *Menu Bar*. Or, click the  button in the *Tool Bar*.

THZ² & TDZ²

Programmable Smart HART
Signal Isolator

Custom Curve

Figure 13. Custom Curve Tab

Point	X data	Y data
1	0	0
2	2	100
3	4	5
4	6	7
5	8	9
6	10	11

Using the Custom Curve feature will disable the Scaling capability. Since both are scaling features used to manipulate the appearance of your process variable, only one of these functions may be used at a time.

Custom Curve—The Custom Curve feature allows you to set up your own custom curve table. This allows you to tell the transmitter what it should output when it receives a certain input. This feature also allows you the ability to write a table in Microsoft® Excel, save it in a .csv format, and import it into the Configuration Software. This makes it simple to save the custom table for downloading to multiple units or for backup purposes.

To create a custom curve:

1. Click the *Enabled* box.
2. Select the number of points for your curve (128 points maximum) and enter it into the *No Of Points* text box.
3. In the *Custom Curve (Y) Range* text boxes, enter the values you wish displayed, and represented as your 4-20mA span, when your input is at its upper and lower ranges.
4. Type your individual values in the *X data* and *Y data* columns. Source variables are inserted into the X Column, while the corresponding data is inserted into the Y Column.
5. After all of your data has been entered, you **must** use the *Custom Curve* dropdown menu to save your newly created custom table (*Save Custom Curve*) and to download it to your instrument (*Download Custom Curve*).

Custom Curve PV Units of Measure— Use this to select a preset HART EGU process variable display for your custom curve values. These HART EGU codes are compatible with HART Revision 5, and earlier, communications.

To customize your display and set your own EGU, open the *Display* screen and use the *Custom Label* feature.

Note:

Once you have configured all parameters, download to the unit by selecting "Download" in the Transfer dropdown menu located in the Status Bar. Or, click the  button in the Tool Bar.

Analog Output

Figure 14. Analog Output Tab

Process Variable Range– Displays the selected process variable range.

Output Range– Sets your output limits. Default value is 4-20mA.

1. Enter your low and high limit values into the text boxes.
2. In the *Under Range Min. Value* box, enter the lowest limit your output can reach before indicating a failure. The allowed limits are 3.6mA to 4.0mA. Default is 3.8mA.
3. In the *Over Range Max. Value* box, enter the highest limit your output can reach before indicating a failure. The allowed limits are 20.0mA to 23.6mA. Default is 21.8mA.

Fail Mode– In the case of an input failure, you have the ability to set an indicator to alert of the failure.

High– Selecting *High* will send the output to a user-selected high value between 20.0mA and 23.6mA. Default is 23.6mA.

Low– By selecting *Low*, the failure indication value will be driven to a user-selectable value between 3.6mA and 4.0mA. Default is 3.6mA.

Note:

When setting Fail Mode to Low on the TDZ2 while it is operating at temperatures below -30 Degree C, set the Output Fail Current to 3.8mA, or higher, to ensure full HART communication functionality.

To select a value other than the default setting for *High* and *Low* fail mode, enter the value into the *Sensor Error Value* text box.

Hold Last– This will maintain the last value present before the failure.

Note:

Once you have configured all parameters, download to the unit by selecting Download in the Transfer dropdown menu located in the Menu Bar. Or, click the  button in the Tool Bar.

Output Current– While in monitoring mode, this displays the present output value.

Trimming– Output Trimming increases the accuracy of your instrument by calibrating its analog output to the device that is receiving the output. This ensures that the instruments are matched to each other.

1. Click the *Lower* button to fix the lower output range.
2. To “fine tune” trimmed values, place the value read on the external ammeter in the *Measured Loop Current* text box and click *Trim*.
3. Click the *Upper* button and repeat Step 2 to trim the upper output range.
4. Once you have performed your output trimming, click *Unfix*.

Note:

Do not click the Reset button in the Trimming menu unless you want to disregard your trimmed values and return to the manufacturer's trim values.

Output Test– This test may be performed in order to check output performance and accuracy and to trim other instruments in your setup. Your output will be a current value, in mA, equal to the value you enter into the text box. You can check the other devices on the system and calibrate them to this signal.

This feature is independent of the input. If you find that the output requires adjustment, you may perform the Trimming function.

1. Ensure that THZ²/TDZ² monitoring is stopped. In the *Fix current* text box, enter a value between 3.6mA and 23.6mA and click the *Fix* button.
2. Return to monitoring the THZ²/TDZ². You will see the “fixed” value in the *Output Current* display and on the external ammeter connected to the output.
3. Once you have finished, stop monitoring your instrument and click *Unfix*.

THZ² & TDZ²

Programmable Smart HART
Signal Isolator

Note:

While performing Analog Output Trimming functions, you may notice a message in the THZ²/TDZ² Status display reading ****OUTPUT FIXED****. Clicking the Unfix button will clear this message.

Searching for a Connected Unit

If using HART Communications and you need to search for a connected THZ² or TDZ² unit with an unknown address, you can perform an address search. An address search sequentially polls short frame addresses 0 through 15 with HART Command 0—*read unique ID*. The first device to respond stops the address search and the device's configuration is uploaded to the PC Configuration Program.

To begin an address search, you may either click the  button on the tool bar or select *Address Search* from the *View* dropdown menu. You can view search progress in the *Address* box located in the *Communications* section of the PC Configuration Program.

Using the HART Communicator

The THZ² and TDZ² can be programmed using a HART Communicator. If your communicator is equipped with the Device Description (DD) for your transmitter, *The HART Communicator Menu with a Device Description* section gives an overview of the menus and instructions for programming.

If your communicator is *not* equipped with the required Device Description, go to *The HART Communicator Menu without a Device Description* section of this manual. Even if your communicator is not up to date, most of the important programming features can be accessed without the THZ² and TDZ² DD by using the Generic HART DD available on HART Communicators.

If you are using a Fisher-Rosemount Model 375 HART Communicator, or other host, you may download the latest Moore Industries DD at www.hartcomm.org. The THZ² and TDZ² DDs are available on the HART Foundation's Device Driver Library Release December 2005 and later.

For installation of the latest device description through the HART Foundation, send the Communicator to the following address:

HART Communication Foundation
9390 Research Blvd., Suite I-350
Austin, TX 78759-6540
USA
Phone: (512) 794-0369
Fax: (512) 794-3904
www.hartcomm.org

Ensure that you contact the HART Foundation to determine their requirements in sending the instrument to their facility.

If you are using a Fisher-Rosemount Model 275 HART Communicator, perform the following steps to determine if your communicator has the appropriate Device Description. With the communicator turned on, press *1* to select *Offline* then press *1* again to select *New Configuration*. A list of companies will appear which, if you have the appropriate Device Description, will include Moore Industries THZ²/TDZ².

If you find that you require the latest version of the DD, you must send the Communicator to Moore Industries. To do this, contact our Customer Service department for a Returned Material Authorization (RMA).

Include Moore Industries' configuration sheet indicating the Device Descriptions that you require. We will load the Device Descriptions of your choice for a nominal charge.

Programming When a Device Description is Available

Note:

All parameters, except the Custom Curve feature, can be configured using the HART Communicator. The Custom Curve table can only be configured using the PC Configuration Software Program.

With the transmitter connected as illustrated in Figures 7 or 8 (depending upon your instrument's housing) apply power and turn on the communicator. After a brief self-test, the communicator will show the main menu and identify the unit as a THZ² or TDZ².

This section contains the instructions for programming the transmitter using a HART Communicator that has been programmed with a HART Device Description. If your communicator does not have the appropriate Device Description, skip to *The HART Communicator Menu without a Device Description* section of this manual.

Figure 15 shows an overview of the programming menus for the configuration process.

Figure 15. THZ² and TDZ² HART Communicator Configuration Menu Summary

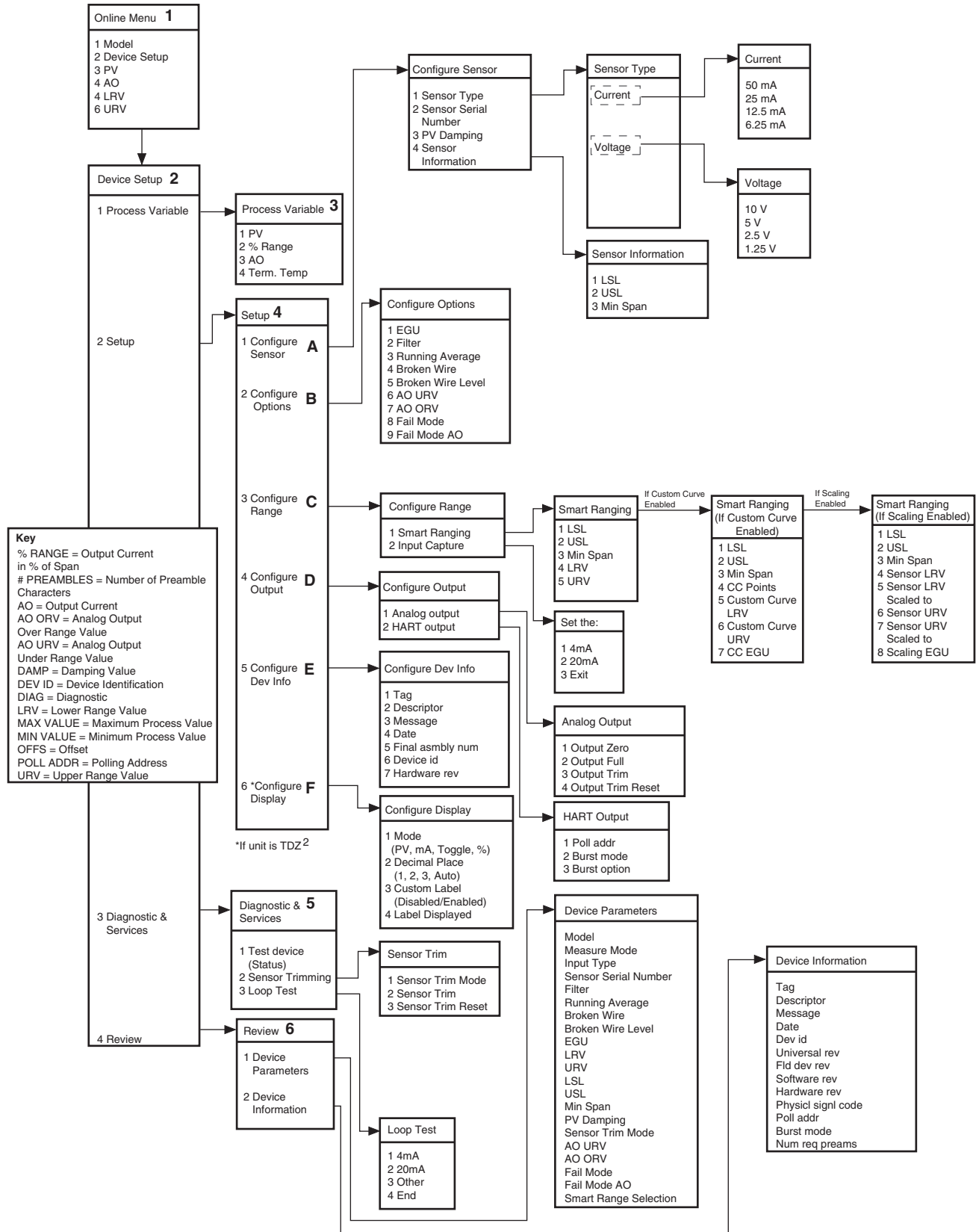

THZ² & TDZ²

Programmable Smart HART
Signal Isolator

The HART Communicator Menu With a Device Description

To program your THZ² or TDZ², if your communicator is equipped with the Device Description for your instrument, follow the steps below. For all steps outlined below, refer to Figure 15 for menu parameters.

1. Online Menu– The *Online* menu displays the current process value of your application, the lower and upper range values and the actual output current. Use the *Device Setup* menu to configure the THZ² and TDZ².

2. Device Setup Menu– The *Device Setup* menu allows you to access the following menus: *Process Variable, Setup, Diagnostic & Services and Review*.

3. Process Variable Menu– The *Process Variable* menu displays the present values of parameters listed on the Communicator display which include the selected EGU, output current in percent of span (% range), analog output and terminal temperature.

4. Setup Menu– Scroll through the *Setup* menu to access configuration menus for the following parameters: *Configure Sensor, Configure Options, Configure Range, Configure Output, Configure Dev Info and Configure Display* (for TDZ² units only).

A. Configure Sensor

This menu allows access to sensor configuration.

1 Sensor Type– Select the sensor type you will use (Current or Voltage). You will navigate through sub-menus depending upon parameters that are being set.

2 Sensor Serial Number– Assign a unique serial number to your sensor.

3 PV Damping– Allows you to introduce a delay into the response of your unit in order to stop short-lived spikes from appearing as faults and generating fault messages. The allowable PV Damping range is 0sec to 30sec.

4 Sensor Information– Displays the Upper Sensor Limit (USL), Lower Sensor Limit (LSL) and minimum span of the selected sensor type.

B. Configure Options

You may configure the THZ² and TDZ² options listed below from the this menu.

1 EGU– View the existing EGU setting.

2 Filter– This is used to configure the input filter which helps reduce mains-induced noise. The value selected should match the frequency of the local AC supply (50Hz or 60Hz).

3 Running Average– This feature filters the input signal. The THZ² and TDZ² provide this feature with a user-selected value between 1 and 16. Factory default is 4.

Note:

A higher Running Average setting provides smoother output transitions, however, will reduce response time. Conversely, a lower setting provides a faster response time, but may seem more unstable.

4 Broken Wire– If enabled, the THZ² and TDZ² monitor the process variable during operation. If the monitored value falls equal to or below a set value, then a state of Broken Wire is declared.

5 Broken Wire Level– In the *Level* textbox, enter the value you choose as your limit. The value that you enter must be greater than zero and less than your *Lower Range* value (see *Configure Range*).

6 AO URV– Select a value between 3.6mA and 22.6mA as your analog output under range value (AO URV). If the analog output drops below the set value, a fault will be declared.

7 AO ORV– Select a value between 4.6mA and 23.6mA as your analog output over range value (AO ORV). If the analog output exceeds the set value, a fault will be declared.

8 Fail Mode– In the case of a sensor failure, this determines how the analog output will respond. You may select a Fail Mode of *High* (proceed to Step 9), *Low* (proceed to Step 9) or *Hold Last* (last value present will be held upon a failure).

Note:

When setting Fail Mode to Low on the TDZ² while it is operating at temperatures below -30 Degree C, set the Output Fail Current to 3.8mA, or higher, to ensure full HART communication functionality.

9 *Fail Mode AO*– Enter a value to correspond to your selection in Step 8. If selecting *High Fail Mode*, enter a value between 20mA to 23.6mA. For *Low Fail Mode*, select a value between 3.6mA to 4.0mA.

Smart Range Selection– Select whether you choose to view the process variable, use a custom curve table or scale the input. Custom curve and input scaling configuration are performed in the *Configure Range* menu.

C. Configure Range

Within the *Configure Range* menu are the capabilities to configure Smart Ranging and capture the input.

1 *Smart Ranging*– Configuration steps will vary depending on whether *PV*, *Custom Curve* or *Input Scaling* was selected in the *Configure Options* menu.

PV

1 *LSL*– Displays the lower sensor limit (LSL) of the attached sensor.

2 *USL*– Displays the upper sensor limit (USL) of the attached sensor.

3 *Min Span*– Indicates the allowable minimum difference between the upper range value (URV) and lower range value (LRV).

4 *LRV*– Enter the value you wish displayed as your low range value when your process variable is output at its lower end (0%).

5 *URV*– Enter the value you wish displayed as your upper range value when your process variable is output at its upper end (100%).

Input Capture– To match your input (zero) and output (full scale) to a known value, use the *Input Capture* feature.

Apply your 0% value to your THZ² or TDZ² and press *Enter* at the prompt. This will set your 4mA value. Repeat this step with a 100% value in order to set your output to a known 20mA. Press *Exit* when you have finished.

If Custom Curve is Enabled

1 *LSL*– Displays the lower sensor limit (LSL) of the attached sensor.

2 *USL*– Displays the upper sensor limit (USL) of the attached sensor.

3 *Min Span*– Indicates the allowable minimum difference between the upper range value (URV) and lower range value (LRV).

4 *CC Points*– Displays the number of Custom Curve points you have enabled (2 to 128 points).

5 *Custom Curve LRV*– Enter your Custom Curve lower range value (LRV) for the lower end output value (0%).

6 *Custom Curve URV*– Enter your Custom Curve upper range value (URV) for the upper end output value (100%).

7 *CC EGU*– Select the EGU you wish displayed for your Custom Curve values.

If Scaling is Enabled

1 *LSL*– Displays the lower sensor limit (LSL) of the attached sensor.

2 *USL*– Displays the upper sensor limit (USL) of the attached sensor.

3 *Min Span*– Indicates the allowable minimum difference between the upper range value (URV) and lower range value (LRV).

4 *Sensor LRV*– Enter the sensor's lower range value (LRV).

5 *Sensor LRV Scaled*– Select the value you wish as your scaled LRV (for 0% output). Allowed span is from -99999 to 99998.

6 *Sensor URV*– Enter the sensor's upper range value (URV).

7 *Sensor URV Scaled*– Select the value you wish as your scaled URV (for 100% output). Allowed span is from -99998 to 99999.

8 *Scaling EGU*– Select the EGU you wish displayed for your scaled input values.

D. Configure Output

This menu allows you to configure your instrument's analog and HART outputs.

Analog Output

Use this portion of the menu to set the *Output Zero* and *Output Full* values, to trim the output and to reset the trimmed output.

1 *Output Zero*– Enter your lower range output current value. Allowed values range from 3.6mA to 23.6mA.

THZ² & TDZ²

Programmable Smart HART Signal Isolator

2 *Output Full*– Enter your upper range output current value. Allowed values range from 3.6mA to 23.6mA.

3 *Output Trim*– Output trimming increases the accuracy of your instrument by calibrating its analog output to the device that is receiving the output. This ensures that the instrument is being correctly interpreted.

Connect a multimeter to your THZ² or TDZ² output to indicate present output reading.

Setting fld device to Output Zero will be displayed on your communicator. Select *OK* if ready to proceed. When prompted, enter the value displayed on the multimeter into your communciator. Press *Enter*. If your output matches the value on the multimeter, select *Yes*.

Next, *Setting fld dev to Out Full* is displayed on your communicator. Select *OK* if ready to proceed. When prompted, enter the value displayed on the multimeter into your communciator. Press *Enter*. If your output matches the value on the multimeter, select *Yes*.

Note:

Do not perform the Output Trim Reset function unless you want to disregard your trim values and return to the manufacturer's values.

HART Output

Use this portion of the menu to configure the Poll Address, Burst mode and Burst Option.

1 *Poll addr*– The HART polling address is represented by a number between 0 and 15. This identifies the transmitter on the loop. In a loop with only one HART slave on it, this address should be 0. In a multidrop loop, any of these numbers can be used.

Note:

If the polling address is set to 0, the transmitter is automatically set to analog mode. Multiple units on the same bus must have different addresses.

2 *Burst mode*– This function allows you to achieve a higher data rate. When enabled (On), your instrument repeatedly transmits a data message as if it were being commanded to do so. The Master device receives the data more frequently than if it were only polling the transmitter, achieving a higher data transfer rate.

Note:

For Fisher-Rosemount HART Communicator, Model 275, you must enable the Burst Mode and send the configuration to the unit before selecting the Burst Option.

3 *Burst option*– Once *Burst Mode* is enabled, choose which value is transmitted–*PV, % range/current* or *Process vars/crnt* (Process variables/current).

E. Configure Dev Info

This menu allows you to configure identification parameters for your THZ² or TDZ².

1 *Tag*– Place a unique label that corresponds to your instruments location or specific usage (8 characters maximum).

2 *Descriptor*– Place text that is used as a description of how the instrument is being used (16 characters, maximum).

3 *Message*– Place additional information that may be helpful in describing the instrument or its use (32 characters, maximum).

4 *Date*– Store a date that corresponds to specific system function, i.e. instrument configuration date, calibration due date, preventive maintenance schedule, etc.

5 *Final asmbly num*– You may enter a number that is used for identification purposes, and is associated with the field device (8 characters, maximum).

6 *Dev id*– This is a read-only value that uniquely identifies the field device when combined with the manufacturer identification and device type.

7 *Hardware rev*– This value corresponds to the revision of the electronics hardware of the field device.

F. Configure Display

This menu only applies to the TDZ² as it is used to configure the manner in which the display is viewed.

1 *Mode*– Select whether your variable is displayed as a PV, current value or a percent.

2 *Decimal Places*– Choose the resolution of your value. Select one, two or three decimal places. You may also choose *Auto* to allow the instrument to automatically select the decimal placement.

3 *Custom Label*– Enable or disable custom label for use on the display.

4 *Label Displayed*– Select your custom label. Enter all capitalized characters or an accepted numeric value.

5. Diagnostic & Service Menu– Allows you to perform diagnostic functions (device test and loop tests) and sensor trimming.

1 *Test device*– Directs you to a *Status* sub-menu. When accessed, it causes the THZ² or TDZ² to perform a self test of its electronics. Any errors that occur are reported on the communicator.

2 *Sensor Trimming*– This menu allows you to view previously configured Sensor Trim Mode settings.

3 *Loop Test*– A loop test may be performed in order to check output performance and accuracy and to trim other instruments in the loop. Your output will be a current value, in mA, equal to the value you input. You can check the other current devices on the loop and calibrate them to this signal.

From the menu, select whether to perform the test at 4mA (low end value), 20mA (upper end value) or at another specified value. Once you have completed your test, select *End*.

It will also allow you to introduce *Device Variable Trim* (Step 4) which allows for calibration measurement of a device variable to be adjusted linearly. You may also enable *Device Variable Trim Reset* (Step 5) which allows for the device variable to be reset to the factory trim default settings.

6. Review Menu–This is a read-only menu that provides information on both *Device Parameters* and *Device Information*. Refer to the *Review* menu portion of Figure 15 for a description of the parameters included in this menu.

THZ² & TDZ²

Programmable Smart HART
Signal Isolator

Figure 16. Generic HART Communicator Menu Overview

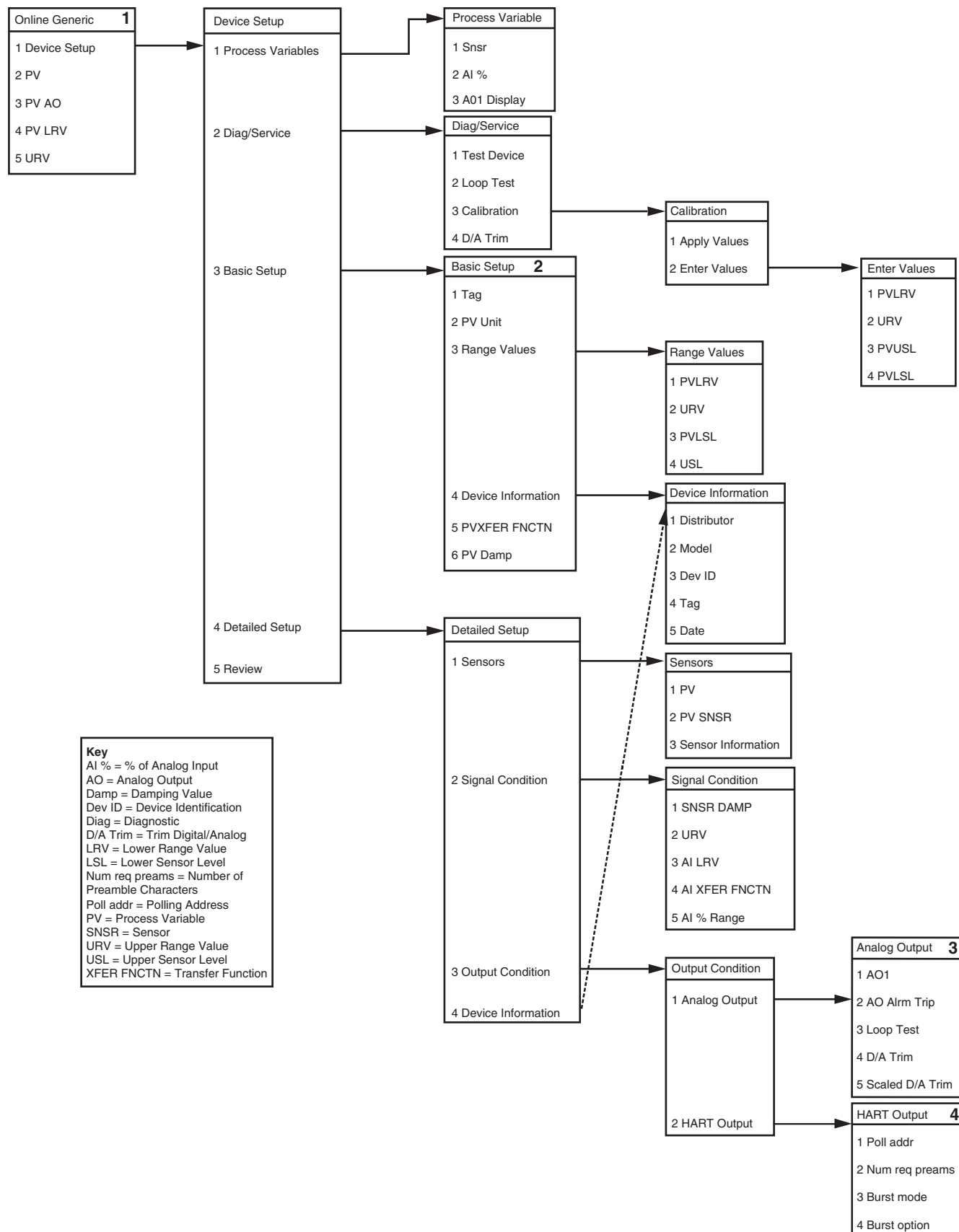

The HART Communicator Menu Without a Device Description

Description

This section contains the instructions for programming a THZ² and TDZ² using a HART communicator without a Device Description. If your communicator has a Device Description, please see *The HART Communicator Menu with a Device Description* section of this manual.

1. Online Generic– The initial screen, the *Online Generic* menu, displays the process value, analog output and the programmed upper and lower parameters of the process value. The generic HART Communicator overview menu (Figure 16) shows the screen. Use the *Device Setup* menu for configuring your THZ² and TDZ².

2. Basic Setup– The *Basic Setup* menu allows you to enter a name for an individual transmitter, the units of measurement, the upper and lower range and sensor values, and a damping time between 0sec and 30sec.

3. Analog Output– The *Analog Output* menu displays the analog output, changes the loop current to a fixed value so that it can be checked against the value being received and displayed by your receiving device, and enters and trims the sensor.

4. HART Output– From the *HART Output* menu, you can enter the polling address and display the number of preamble characters sent by the master to the slave to ensure synchronization.

If the polling address is set to 0, the THZ² and TDZ² is automatically set to analog mode. Multiple units on the same bus **must** have different addresses.

Figure 17. Connecting the THZ² or TDZ² in Multidrop Configuration

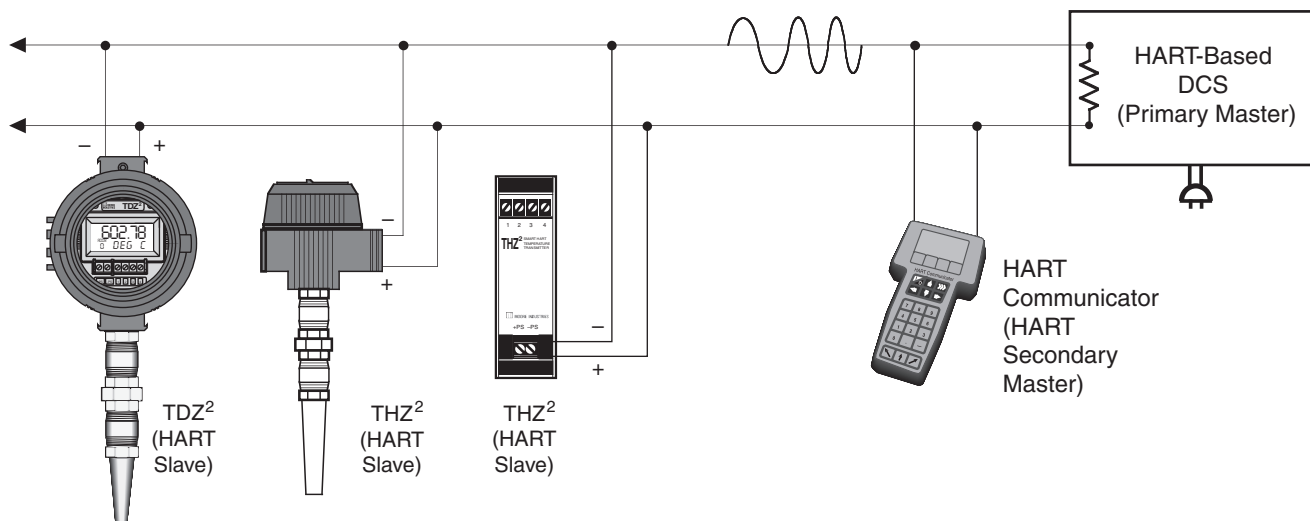

THZ² & TDZ²

Programmable Smart HART

Signal Isolator

HART Status Information

Each time the THZ² and TDZ² generate a response, frame status information is included in the reply message. The first byte indicates communications errors, if any. Otherwise, if communication was good, this byte may indicate the status of the received command (such as *transmitter busy* or a *command not supported*). The second status byte indicates the operational state of the slave device. A properly operating slave device will have both status bytes set to logic zero.

The following tables include the common information that is returned in every response message. However, they do not detail the transmitter-specific *Additional Status Information* that is returned in the data portion of the response to *HART Command 48*. You may access the *Additional Status Information* window via the *View* dropdown menu in the tool bar.

Table 4. Communications Errors

Bit 7 = 1	
Bit	Description
0	Undefined
1	Buffer Overflow
2	Reserved set to zero
3	Checksum Error
4	Framing Error
5	Overrun Error
6	Parity Error
7	This bit is always set when Communication errors occur

Table 5. Command Errors

Bit 7 = 0		
Value	Hex	Description
0	0x00	No command Errors
1	0x01	Undefined Error
2	0x02	Invalid selection
3	0x03	Passed Parameter too large
4	0x04	Passed Parameter too small
5	0x05	Too Few bytes received
6	0x06	Transmitter Specific Command Error
18	0x12	Invalid UOM Code
32	0x20	Transmitter Busy
64	0x40	Command not supported

Table 6. Device Status Bytes Table

Bit	Type	Description
0	Error	Primary Variable Out of Limits. The process applied to the sensor for the Primary Variable is beyond the operating limits of the device.
1	Error	Non-Primary Variable Out of Limits. The process applied to a sensor, other than that of the Primary Variable, is beyond the operating limits of the device. <i>Command #48, Additional Status Information</i> , may be required to identify the variable.
2	Error	Analog Output Saturated. The analog and digital outputs for the Primary Variable are beyond their limits and no longer represent the true applied process.
3	Error	Analog Output Current Fixed. The analog and digital outputs for the Primary Variable are held at the requested value. They will not respond to the applied process.
4	Error	Additional Status Available. More status information is available than can be returned in the Field Device Status. <i>Command #48, Additional Status Information</i> may be required to identify the variable.
5	Error	Cold Start. Power has been removed and reapplied resulting in the reinstallation of the setup information. The first command to recognize this condition will automatically reset this flag. This flag may also be set following a Master Reset or a Self Test.
6	Error	Configuration Changed. A write or set command has been executed.
7	Error	Device Malfunction. A hardware error or failure has been detected by the device. Further information may be available through <i>Command #48, Additional Status Information</i> .

TDZ² Displayed Error Messages

The TDZ² will need to be sent back to Factory for repair is any of the messages shown in Table 7. are displayed.

Table 7. TDZ² Displayed Messages

Error Condition	Displayed Message
Hardware failure	ERROR HWARE
EEPROM failure	ERROR EEROM
Calibration data bad	ERROR CALIB
Configuration or calibration data checksum mismatch	ERROR CKSUM
EEPROM blank	ERROR BLANK
Process variable out of range (< -99999 or > +99999)	ERROR RANGE
Maths division by zero error	ERROR DZERO
Configuration information bad	ERROR CONFG
Software watchdog failure	ERROR SWARE
Input saturation condition	ERROR INSAT
Front-end comms error condition	ERROR F END
Other or combination of errors	ERROR

THZ² & TDZ²

Programmable Smart HART
Signal Isolator

HART Command 48

The *Additional Status Information* section in the *View* dropdown menu returns five additional HART status information bytes in response to HART Command 48—*Read Additional HART Status Information*.

The five data bytes are described in Table 8.

Table 8. HART Command 48 Data Bytes

Status Byte	Status Word Bit	Type	Description
0	0	Error	Configuration data error
	1	Error	Calibration data error
	2	Error	EEPROM blank
	3	Error	EEPROM failure
	4	Error	Division by zero error
	5	Not used	Set to zero
	6	Error	Software watchdog failure
	7	Error	COP watchdog failure
1	0	Not used	Set to zero
	1	Not used	Set to zero
	2	Not used	Set to zero
	3	Status	Sensor wires broken
	4	Not used	Set to zero
	5	Status	Input Saturation
	6	Status	Busy / Calibration, trimming active
	7	Error	Configuration data area checksum error
2	0	Error	Calibration data area checksum error
	1	Error	ADC Error
	2	Error	Bad custom curve
	3	Error	Front-end / Back-end communications failure
	4-7	Not used	Set to zero
3	0-7	Not used	Set to zero
4	0-7	Not used	Set to zero
5	0-7	Not used	Set to zero

Installation

Installation consists of physically mounting the unit and completing the electrical connections.

Mounting the THZ² or TDZ²

The THZ² HPP fits inside a 30-35mm connection head (such as the LH1) using captive mounting screws. The THZ DIN² can be mounted on standard DIN mounting rails. The TDZ² HP can be mounted with rails, flanges, or in one of our larger housings, such as the D-BOX or BH.

Making the Electrical Connections

The connections for the various inputs are shown in Figures 7 and 8. The figure shows a single transmitter. If you are using multiple units, connect them using the connections shown in Figure 17.

In multi-drop networks, the unit's receiving device is normally a HART-communicating control system acting as the HART Primary Master. The control system uses each transmitter's individual address to access real-time process data, sensor diagnostics and THZ² or TDZ² diagnostic data. The address is also used to locate the appropriate unit, to initiate configuration and to calibrate. A HART communicator, acting as the HART Secondary Master, can be used to simultaneously access information from, or transmit configuration information to the transmitter from anywhere along the HART digital link.

Make sure that the total loop resistance is at least 250 ohms so that the 4-20mA signal containing the HART protocol is not shorted. If loop resistance is less than 250 ohms, add a resistor.

Recommended Ground Wiring Practices

Moore Industries recommends the following ground wiring practices:

- Any Moore Industries product in a metal case or housing should be grounded.
- The protective earth conductor must be connected to a system safety earth ground before making other connections.
- All input signals to, and output signals from, Moore Industries' products should be wired using a shielded, twisted pair wiring technique. Shields should be connected to an earth or safety ground.
- For the best shielding, the shield should be run all the way from the signal source to the receiving device. (see Note below)
- The maximum length of unshielded input and output signal wiring should be 2 inches.

Note:

Some of Moore Industries' instruments can be classified as receivers (IPT², IPX², etc.) and some can be classified as transmitters (TRX, TRY, etc.) while some are both a receiver and a transmitter (SPA², HIM, etc). Hence, your shield ground connections should be appropriate for the type of signal line being shielded. The shield should be grounded at the receiver and not at the signal source.

Switches and Circuit Breakers

A switch or circuit breaker must be wired in series with the AC power conductors. The switch or circuit breaker used must be located within three meters of the unit.

WARNING:

Terminals on this unit may be connected to hazardous voltages. Before making ANY connections to this unit, ALL hazardous voltages must be de-energized.

The circuit breaker or switch will only remove power to the unit, hazardous voltages may still be connected to other terminals on the unit.

Installation Category

All of Moore Industries' terminals are rated CAT II, except those with the -RF option. These terminals are rated CAT I.

THZ² & TDZ²

Programmable Smart HART
Signal Isolator

Equipment Ratings

The THZ² and TDZ² do not generate hazardous voltages, rather, they accommodate a current or voltage input, and generate a low voltage current output. Products connected to the THZ² or TDZ² should be designed to receive these inputs.

Supply Wiring

All power connections should be made with the proper wire.

The end of each conductor should be stripped no more than 8mm (0.31 in). The end of the stripped wire should be tinned with solder, or inserted into a ferrule and crimped before being placed into a terminal block.

Conductors connected to screw-type connections should have a ring-lug or spade-lug crimped onto the wire end.

CE Conformity

Installation of any Moore Industries' products that carry the CE marking must adhere to the guidelines in the Recommended Ground Wiring Practices section in order to meet the EN 61326 requirements set forth in the applicable EMC directive.

Installation in Hazardous Locations

This page contains information for the THZ² and TDZ² instruments when used within an intrinsically-safe system.

The diagram on the following page must be used for units that are to operate in areas requiring intrinsically-safe instrumentation.

Refer to the *Special Conditions* outlined below before proceeding with installation.

Special Conditions of Use

The following instructions must be adhered to when the THZ² and TDZ² are used in hazardous 'Classified' locations and potentially explosive atmospheres.

I. Intrinsically Safe (Ex ia) Applications (Zones 0 and 1)

1. The Models THZ² and TDZ² Temperature Transmitters shall be installed in a final enclosure rated for a minimum of IP20.
2. For Zone 0 installations, the final enclosure shall not contain more than 10% in total of aluminum, magnesium, titanium and zirconium, or 7.5% in total of magnesium, titanium and zirconium.
3. For Zone 1 installations, the final enclosure shall not contain 7.5% in total of magnesium.
4. Wiring must be rated for 85°C.

II. Type N (Ex n) Applications (Zone 2)

1. As Category 3 equipment, the Models THZ² and TDZ² Temperature Transmitters shall be installed in an enclosure which maintains an ingress protection of IP54 and meets the enclosure requirements of EN60079-0 and EN60079-15.
2. The Models THZ² & TDZ² Temperature Transmitters shall contain external transient protection to prevent the supply voltage from exceeding 46.2V including tolerance.
3. Wiring must be rated for 85°C.

Safety Concerns

For your safety, read the following information carefully before proceeding with installation.

WARNING: EXPLOSION HAZARD – FOR DIVISION 2 HAZARDOUS LOCATIONS. DO NOT DISCONNECT EQUIPMENT WHEN A FLAMMABLE ATMOSPHERE IS PRESENT.

WARNING: SUBSTITUTION OF COMPONENTS IS NOT ALLOWED AS IT MAY IMPAIR THE INTRINSIC SAFETY (ZONES 0 & 1, DIVISION 1) OF THE UNIT AND/OR THE NON-INCENDIVE/TYPE N (DIVISION 2, ZONE 2) CIRCUIT. DO NOT OPEN THE UNIT WHEN EITHER ENERGIZED OR WHEN AN EXPLOSIVE GAS/DUST ATMOSPHERE IS PRESENT. DISCONNECT POWER BEFORE SERVICING. READ AND UNDERSTAND THE MANUFACTURER'S INSTALLATION AND OPERATING PROCEDURES, AND ADHERE TO ALL APPLICABLE ELECTRICAL CODES, SAFETY INSTRUCTIONS AND REGULATIONS.

AVERTISSEMENT – RISQUE D'EXPLOSION. NE PAS DEBRANCHER TANT QUE LE CIRCUIT EST SOUS TENSION, A MOINS QU'IL NE S' AGISSE D'UN EMPLACEMENT NON DANGEREUX.

WARNING: END-USER MUST MARK EITHER CHECKER BOX ON THE INSTRUMENT ID LABEL WITH THE INTENDED APPLICATION – INTRINSICALLY SAFE OR TYPE N / NON-INCENDIVE.

THZ² & TDZ²

Programmable Smart HART
Signal Isolator

Operation

Once programmed, calibrated, installed and supplied with the correct power, THZ² and TDZ² transmitters begin to operate immediately. Depending upon environmental conditions, they can be expected to operate unattended for extended periods of time.

HART Protocol

This section of the manual gives an overview of the HART format used by THZ² and TDZ² modules during operation. Use the information in this section to process the data provided by the module(s) during operation. For more information on the HART protocol, contact the HART Foundation at:

HART Communication Foundation
9390 Research Blvd., Suite I-350
Austin, TX 78759-6540
USA
Phone: (512) 794-0369
Fax: (512) 794-3904
www.hartcomm.org

Device Types

To implement two-way communication between the THZ² and the device being used to configure it or receive its information, the THZ² and TDZ² operate in a HART Master/Slave structure. The THZ² or TDZ² is the Slave (or slaves in a multidrop network).

There can be two Masters per system: a Primary Master and a Secondary Master. Masters are typically either a HART Hand-Held Communicator or a HART-based control system.

In many applications, the Primary Master is a HART Hand-Held Communicator. The communicator is used solely as a configuration tool to set up the transmitter, periodically view its real-time process measurement, or view its operating and diagnostic information from a loop termination point.

Digital Signal

One of the advantages of the HART protocol is that the digital information is conveyed by the same wires used to output the 4-20mA signal. After being polled by the master, the THZ² or TDZ² responds to the inquiry by modulating the 4-20mA current 0.5mA above or below the output signal. 1200 Hz represents 1 and 2200 Hz represents 0.

Communication Speed and Format

The speed of the HART transmission is 1200 bps. The time delay between a master initiating a request for data from a slave and the slave receiving and acknowledging the request depends upon which command is issued. Generally, a master can poll a slave 2-3 times per second.

The byte structure of the HART signal is:

1 Start Bit, 8 Data Bits, 1 Odd Parity Bit, 1 Stop Bit.

Maintenance

Moore Industries suggests a quick check for terminal tightness and general unit condition every 6-8 months. Always adhere to any site requirements for programmed maintenance.

Customer Support

If service assistance is ever required for an device in your application, refer to the back cover of this manual for the telephone numbers to Moore Industries' customer service department.

If possible, make a note of the model number of the unit before calling. For fastest assistance, have the following information available: serial number, the job number and purchase order number under which it was shipped

Refer to the Safety Concerns section on the previous page before continuing with installation.

DO NOT SCALE DRAWING		CONTROL DRAWING		DRAWING NUMBER		REVISION	
DRAWN GUS H. ELIAS		GUS H. ELIAS		100-100-71		A	
CHECKED S.K.		S.K.		DATE		BY	
ENGINEER GUS H. ELIAS		GUS H. ELIAS		06/07		G.E.	
SCALE NONE		NONE		REVISED BY		APPROVAL	
TOLERANCES (UNLESS NOTED)		TITLE		INITIAL RELEASE		CB	
DECIMALS = ± inch/mm		Field Installation Diagram: TDZ2 [HP] & THZ2 [HPP] Intrinsically Safe System For Hazardous 'Classified' Locations		06/07		06/07	
.X = ±.1 / 2.54							
.XX = ±.03 / 0.76							
.XXX = ±.0100 / 0.25							
HOLES = ±.003-.0024-.06-.05							
ANGLES: = ± 30'							
MOORE INDUSTRIES							
NOTICE RE PROPRIETARY INFORMATION: This drawing and the information contained herein are the proprietary property of Moore Industries-International, Inc. (MI) and should not be reproduced or disclosed to any third party without the written consent of an authorized officer of MI.							

CERTIFIED PRODUCT
This is a controlled 'Related' or 'Schedule' drawing. No modifications are permitted without the notification and final approval of the Certification Engineer (related dwgs.) or the Certifying Agency (schedule dwgs.).

Caution: The 'COM' Port Must Not Be Used In Hazardous 'Classified' Locations.
TDZ2 [HP]: 4-20 mA PC-Programmable Smart HART Temperature Transmitter w/ Display
THZ2 [HPP]: 4-20mA PC-Programmable Smart HART Temperature Transmitter

DO NOT SCALE DRAWING
FIELD INSTALLATION DIAGRAM:
TDZ2 [HP] & THZ2 [HPP]
INTRINSICALLY SAFE SYSTEM
FOR HAZARDOUS 'CLASSIFIED' LOCATIONS

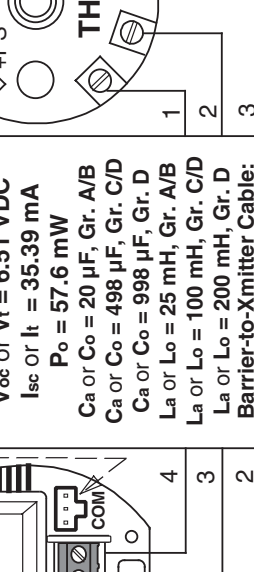

Sensor Type - mA, mV, POT, RTD, Ω, T/C:
V_{oc} or V_t = 6.51 VDC
I_{sc} or I_t = 35.39 mA
P_o = 57.6 mW
C_a or C_o = 20 μF, Gr. A/B
C_a or C_o = 498 μF, Gr. C/D
C_a or C_o = 998 μF, Gr. D
L_a or L_o = 25 mH, Gr. A/B
L_a or L_o = 100 mH, Gr. C/D
L_a or L_o = 200 mH, Gr. D
Barrier-to-Xmitter Cable:
≤ 3,575 ft, 214.5 nF, Gr. A/B
≤ 103,166 ft, 6.19 μF, Gr. C/D
≤ 423,166 ft, 25.39 μF, Gr. D

I.S. Entity Parameters (Power/Loop, +PS & -PS):
V_{max} or U_i = 30 VDC
I_{max} or I_i = 110 mA
P_{max} or P_i = 0.825 W
C_i = 5.83 nF
L_i = 0 H
C_a or C_o ≥ C_i + C_{cable}
L_a or L_o ≥ L_i + L_{cable}
V_{max} or U_i ≥ V_{oc} or V_t
I_{max} or I_i ≥ I_{sc} or I_t

Input device must be "Agency-Approved" per application area (CSA, FM, IISep, KEMA, LCIE, UL, TestSafe, SIRA, TUV, etc....)

Hazardous 'Classified' Locations/Areas
US (NEC 500/505) / Canada (C22.2-1010.1)
Intrinsically Safe & Non-Incendive
Class I, Zone 0, AEx ia IIC, (T4 / T5 / T6)*
Class I; Divisions 1 & 2; Groups A-D
ATEX: II 1G Ex ia IIC, II 3G Ex nA IIC, (T4 / T5 / T6)*
IECEX: Ex ia IIC, Ex nA IIC, (T4 / T5 / T6)*
*T. Codes: T4@85°C (TDZ2), T5@85°C/T6@60°C (THZ2)
Operating Temperature Range: -40°C ≤ Tamb. ≤ +85°C

Notes:
1- Apparatus which is unspecified except that it must not be supplied from, or contain under normal or abnormal conditions a source of potential with respect to earth in excess of 250 VRMS or 250 VDC which is considered to be the Safe Area's maximum voltage.
2- The Barrier or other Associated Apparatus must be agency-approved (CSA/FM/SAA/SIRA/UL, etc.) per the "specific" installation area for Intrinsically Safe connections (Zones 0/1, Class I / Div. 1). US barriers for USA, Canadian barriers for Europe, IECEx barriers where applicable. The output voltage (V_{oc}, V_t or V_o) must not exceed 30 VDC & the output current (I_{sc}, I_t or I_o) must not exceed 110 mA. Also, it must be installed per the manufacturer's guidelines. A Shunt Zener Barrier is NOT required for Non-Incendive / Type N installations.
3- The combined Capacitance and Inductance of the inter-connecting cables of the device (hazardous area) must not exceed the values indicated on the Associated Apparatus (safe area).
4- For US applications, installation must be in accordance to 'ANSI-P12.6' (Installation of I.S. Systems for Hazardous 'Classified' Locations) and the National Electric Code 'ANSI/NFPA 70'. Also, a dust-tight conduit seal must be used when installed in Class II and Class III environments. For applications in Canada, adhere to the 'Canadian Electric Code C22.1' most current publication on I.S. installation guidelines. For CENELEC/ATEX and IECEx applications, adhere to 'EN 60079-14:1997' or any equivalent IEC-based, most current and pertaining publication on I.S. installation guidelines.
5- Warning: Substitution of components is NOT allowed as it may impair the Intrinsic Safety of the unit and/or the Non-Incendive circuit. DO NOT open the unit when either energized or if an explosive gas/dust atmosphere is present. Disconnect power before servicing. Also read, understand and adhere to the manufacturer's installation and operating procedures.
6- The maximum power parameters of the COM port (to be used only in safe/non-hazardous areas) are: V_{max} = 3.0 VDC, I_{max} = 300 μA, P_{max} = 240 μW.

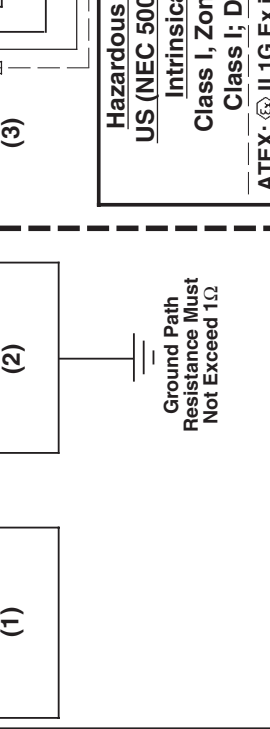

IECEX Ex FM US APPROVED 0518

For areas classified with "dust-hazard" (Class II/III, Division 1, Groups E, F & G), these devices must be mounted in approved protective enclosures that are rated and suitable for use in the designated application areas. Use +85°C rated electrical wire.

	DO NOT SCALE DRAWING		CATEGORY		DRAWING NUMBER		REVISION
	TOLERANCES (UNLESS NOTED) DECIMALS = ±.001 / 2.54 .XX = ±.03 / 0.76 .XXX = ±.010 / 0.25 HOLES: ±.003 / .0025 / .08 - .06 ANGLES: = ± 30°	DRAWN Gus H. Elias CHECKED S.K. ENGINEER Gus H. Elias SCALE 1/1	06/07 06/07 06/07	COMPUTERIZED LABEL REAR ID LABEL TDZ2 [HP]: 4-20mA HART Temp. X-mitter Intrinsically Safe: 12-30Vdc Gen. Loc., N.I., Type N: 12-42Vdc ATEX, cFMus, IECEX.	200-251-2207 INITIAL RELEASE 06/07 G.E.	BY G.E.	APPROVAL CB
NOTICE RE PROPRIETARY INFORMATION: This drawing and the information contained herein are the proprietary property of Moore Industries-International, Inc. (MII) and should not be reproduced or disclosed to any third party without the written consent of an authorized officer of MII.							

CERTIFIED PRODUCT
 This is a controlled 'Related' or 'Schedule' drawing. No modifications are permitted without the notification and approval of the Certification Engineer (related dwgs.) or the Certifying Agency (schedule dwgs.).

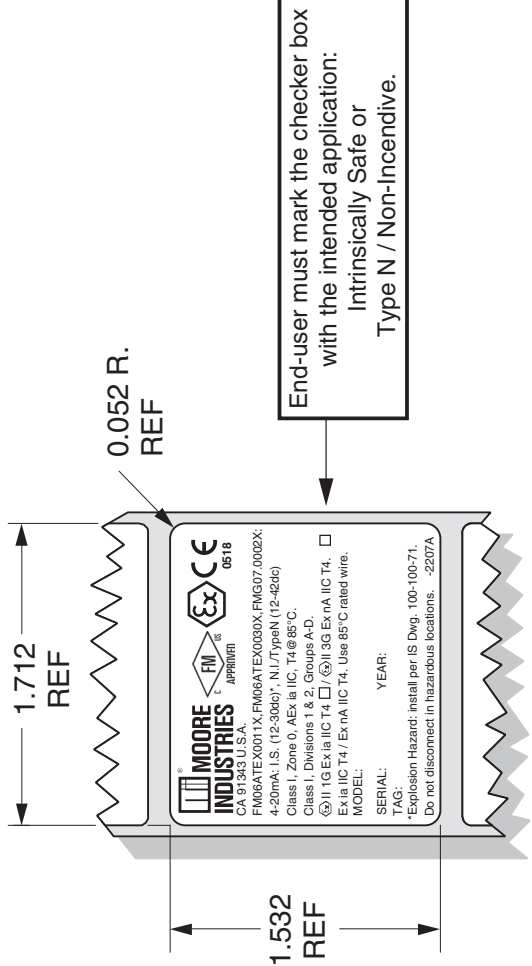

End-user must mark the checker box with the intended application:
 Intrinsically Safe or
 Type N / Non-Incendive.

NOTES:

1. TO PRINT THIS LABEL: JOB SPECIFIC MODEL, SERIAL, YEAR AND TAG NUMBERS WILL BE DOWNLOADED FROM THE MENTOR DATA FILE AND PRINTED ALONG WITH THE FIXED TEXT AND GRAPHICS (SUPPLIED BY THE LEGI 93 DATA FILE) TO CREATE THE FINISHED LABEL.
2. THE FIXED TEXT AND GRAPHIC FIELDS FOR THIS LABEL ARE STORED UNDER NO. 200-251-2207 IN THE LEGI 93 LABEL MACHINE COMPUTER HARD DISK.
3. MATERIAL: .002 SILVER, IDENTIPLATE (MII P/N 200-301-00) DIE CUT AS SHOWN ABOVE. REFER TO LABEL SPEC. DRAWING 200-301-00.

	DO NOT SCALE DRAWING		CATEGORY COMPUTERIZED LABEL		DRAWING NUMBER 200-251-2208		REVISION A
	TOLERANCES (UNLESS NOTED) DECIMALS = ±.1 / 2.54 .XX = ±.03 / 0.76 .XXX = ±.0100 / 25 HOLES: ±.005-.0024-.08-.06 ANGLES: = ± 30'	DRAWN Gus H. Elias CHECKED S.K. ENGINEER Gus H. Elias SCALE 1/1	DATE 06/07 DATE 06/07 DATE 06/07	REVISION A	REVISION A	REVISION A	REVISION A
COMPUTERIZED LABEL ID LABEL THZ2 [HPP]: 4-20mA HART Temp. X-mitter Intrinsically Safe: 12-30Vdc Gen. Loc, N.I., Type N: 12-42Vdc ATEX, cFMus, IECEX.		TITLE ID LABEL THZ2 [HPP]: 4-20mA HART Temp. X-mitter Intrinsically Safe: 12-30Vdc Gen. Loc, N.I., Type N: 12-42Vdc ATEX, cFMus, IECEX.		REVISION A		REVISION A	

NOTICE RE PROPRIETARY INFORMATION: This drawing and the information contained herein are the proprietary property of Moore Industries-International, Inc. (MII) and should not be reproduced or disclosed to any third party without the written consent of an authorized officer of MII.

CERTIFIED PRODUCT
 This is a controlled 'Related' or 'Schedule' drawing. No modifications are permitted without the notification and final approval of the Certification Engineer (related dwgs.) or the Certifying Agency (schedule dwgs.).

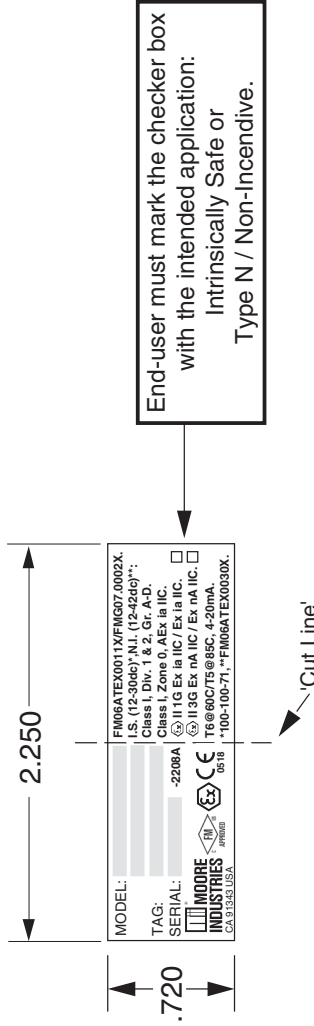

NOTES:

1. TO PRINT THIS LABEL: JOB SPECIFIC MODEL, SERIAL, AND TAG NUMBERS WILL BE DOWNLOADED FROM THE MENTOR DATA FILE AND PRINTED ALONG WITH THE FIXED TEXT AND GRAPHICS (SUPPLIED BY THE LEGI 93 DATA FILE) TO CREATE THE FINISHED LABEL.
2. THE FIXED TEXT AND GRAPHIC FIELDS FOR THIS LABEL ARE STORED UNDER NO. 200-251-2208 IN THE LEGI 93 LABEL MACHINE COMPUTER HARD DISK.
3. MATERIAL: .002 SILVER, IDENTIPLATE (MII P/N 200-304-00) DIE CUT AS SHOWN ABOVE. REFER TO LABEL SPEC. DRAWING 200-304-00.

RETURN PROCEDURES

To return equipment to Moore Industries for repair, follow these four steps:

1. Call Moore Industries and request a Returned Material Authorization (RMA) number.

Warranty Repair –

If you are unsure if your unit is still under warranty, we can use the unit's serial number to verify the warranty status for you over the phone. Be sure to include the RMA number on all documentation.

Non-Warranty Repair –

If your unit is out of warranty, be prepared to give us a Purchase Order number when you call. In most cases, we will be able to quote you the repair costs at that time. The repair price you are quoted will be a "Not To Exceed" price, which means that the actual repair costs may be less than the quote. Be sure to include the RMA number on all documentation.

2. Provide us with the following documentation:
 - a) A note listing the symptoms that indicate the unit needs repair
 - b) Complete shipping information for return of the equipment after repair
 - c) The name and phone number of the person to contact if questions arise at the factory
3. Use sufficient packing material and carefully pack the equipment in a sturdy shipping container.
4. Ship the equipment to the Moore Industries location nearest you.

The returned equipment will be inspected and tested at the factory. A Moore Industries representative will contact the person designated on your documentation if more information is needed. The repaired equipment, or its replacement, will be returned to you in accordance with the shipping instructions furnished in your documentation.

WARRANTY DISCLAIMER

THE COMPANY MAKES NO EXPRESS, IMPLIED OR STATUTORY WARRANTIES (INCLUDING ANY WARRANTY OF MERCHANTABILITY OR OF FITNESS FOR A PARTICULAR PURPOSE) WITH RESPECT TO ANY GOODS OR SERVICES SOLD BY THE COMPANY. THE COMPANY DISCLAIMS ALL WARRANTIES ARISING FROM ANY COURSE OF DEALING OR TRADE USAGE, AND ANY BUYER OF GOODS OR SERVICES FROM THE COMPANY ACKNOWLEDGES THAT THERE ARE NO WARRANTIES IMPLIED BY CUSTOM OR USAGE IN THE TRADE OF THE BUYER AND OF THE COMPANY, AND THAT ANY PRIOR DEALINGS OF THE BUYER WITH THE COMPANY DO NOT IMPLY THAT THE COMPANY WARRANTS THE GOODS OR SERVICES IN ANY WAY.

ANY BUYER OF GOODS OR SERVICES FROM THE COMPANY AGREES WITH THE COMPANY THAT THE SOLE AND EXCLUSIVE REMEDIES FOR BREACH OF ANY WARRANTY CONCERNING THE GOODS OR SERVICES SHALL BE FOR THE COMPANY, AT ITS OPTION, TO REPAIR OR REPLACE THE GOODS OR SERVICES OR REFUND THE PURCHASE PRICE. THE COMPANY SHALL IN NO EVENT BE LIABLE FOR ANY CONSEQUENTIAL OR INCIDENTAL DAMAGES EVEN IF THE COMPANY FAILS IN ANY ATTEMPT TO REMEDY DEFECTS IN THE GOODS OR SERVICES, BUT IN SUCH CASE THE BUYER SHALL BE ENTITLED TO NO MORE THAN A REFUND OF ALL MONIES PAID TO THE COMPANY BY THE BUYER FOR PURCHASE OF THE GOODS OR SERVICES.

ANY CAUSE OF ACTION FOR BREACH OF ANY WARRANTY BY THE COMPANY SHALL BE BARRED UNLESS THE COMPANY RECEIVES FROM THE BUYER A WRITTEN NOTICE OF THE ALLEGED DEFECT OR BREACH WITHIN TEN DAYS FROM THE EARLIEST DATE ON WHICH THE BUYER COULD REASONABLY HAVE DISCOVERED THE ALLEGED DEFECT OR BREACH, AND NO ACTION FOR THE BREACH OF ANY WARRANTY SHALL BE COMMENCED BY THE BUYER ANY LATER THAN TWELVE MONTHS FROM THE EARLIEST DATE ON WHICH THE BUYER COULD REASONABLY HAVE DISCOVERED THE ALLEGED DEFECT OR BREACH.

RETURN POLICY

For a period of thirty-six (36) months from the date of shipment, and under normal conditions of use and service, Moore Industries ("The Company") will at its option replace, repair or refund the purchase price for any of its manufactured products found, upon return to the Company (transportation charges prepaid and otherwise in accordance with the return procedures established by The Company), to be defective in material or workmanship. This policy extends to the original Buyer only and not to Buyer's customers or the users of Buyer's products, unless Buyer is an engineering contractor in which case the policy shall extend to Buyer's immediate customer only. This policy shall not apply if the product has been subject to alteration, misuse, accident, neglect or improper application, installation, or operation. THE COMPANY SHALL IN NO EVENT BE LIABLE FOR ANY INCIDENTAL OR CONSEQUENTIAL DAMAGES.



WORLDWIDE • www.miinet.com

United States • info@miinet.com
Tel: (818) 894-7111 • FAX: (818) 891-2816
Australia • sales@mooreind.com.au
Tel: (02) 8536-7200 • FAX: (02) 9525-7296

Belgium • info@mooreind.be
Tel: 03/448.10.18 • FAX: 03/440.17.97
The Netherlands • sales@mooreind.nl
Tel: (0)344-617971 • FAX: (0)344-615920

China • sales@mooreind.sh.cn
Tel: 86-21-62491499 • FAX: 86-21-62490635
United Kingdom • sales@mooreind.com
Tel: 01293 514488 • FAX: 01293 536852